



APPLICATION NOTES FOR SATEL RADIO MODEMS

Remote monitoring and control of a water supply plant

A regional water company operating in the neighbourhood of the city of Kielce in Poland manages a water supply plant including water intakes and a Dispatch Station. The plant constitutes a part of the water supply network of the city.

In order to improve the efficiency of the supply system by means of better control of the water intakes, the water company decided in 1999 to implement a monitoring-control system for the facilities mentioned above.

The control system for the water intakes is based on PLC programmable controllers. Two computers, interconnected through an Ethernet network, are used for monitoring of the process data and for execution of the process control commands. One of the computers is installed at the Dispatch Station, and the other, acting as a backup unit,

at the headquarters of the water company.

Wireless communication through radio modems

The communication between the controllers installed at the intakes and the computer at the Dispatch Station is based on data transmission by SATELLINE-2ASxE radio modems produced by SATEL. A controller installed at an intake close to the Dispatch Station is cable connected to the computer. In both cases the transmission of data occurs on the basis of the Modbus RTU protocol.

The controllers installed at the intakes deliver – through the SATEL radio modems – measurement data on the critical process parameters, signals related to alarm conditions and failures, data on the running hours of the pumps and amount of output water, as well as control operations like settings of the throttle valves.

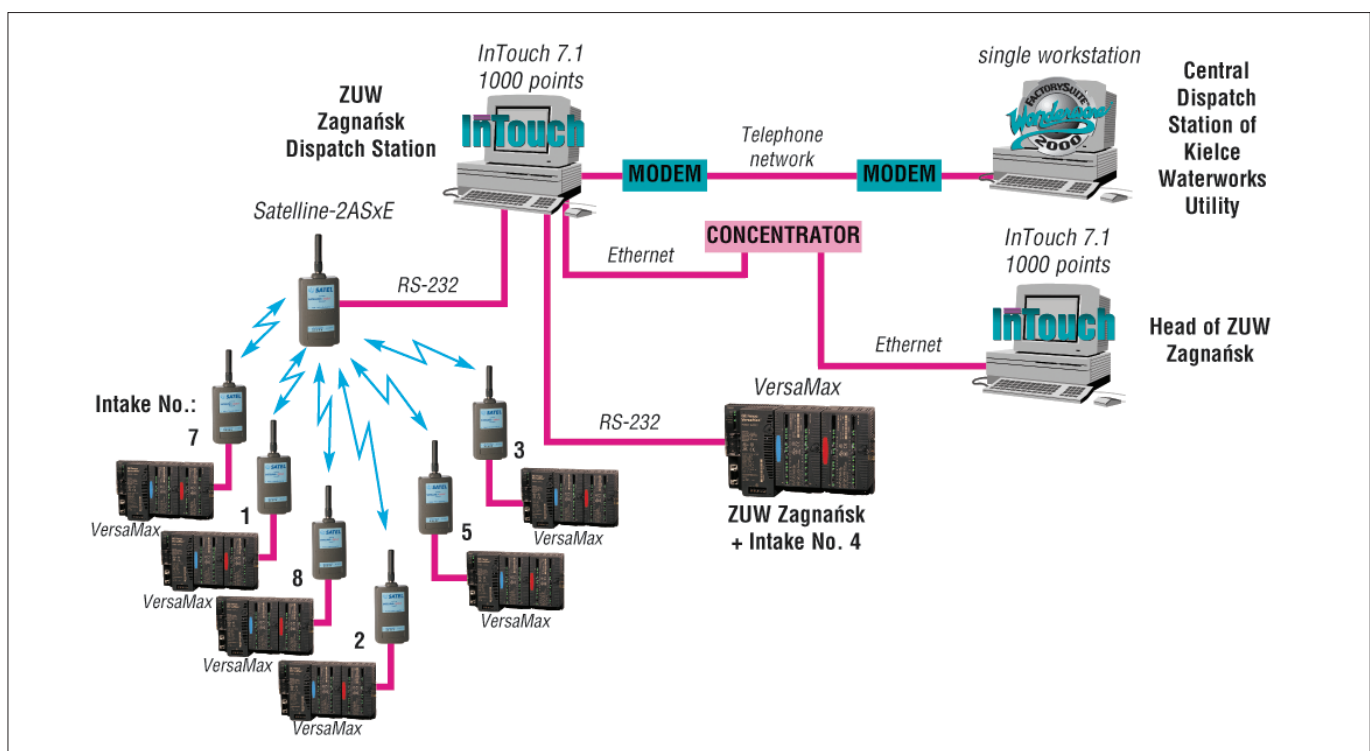

Diagram of the controlling system

APPLICATION NOTES FOR SATEL RADIO MODEMS

The controller at each one of the water intakes is connected to a SATELLINE-2ASxE radio modem, which transmits the measurement data and the data generated by the controller to the SATELLINE-2ASxE connected to the computer at the Dispatch Station.

The visualisation of the process data is composed of a number of different screens including, for example, engineering diagrams, alarm screens, trend displays and information screens. Reports on water production and running time of the pumps at artesian wells and pump units at the intakes, can be generated on daily or monthly basis.

The monitoring-control system implemented provides the operator with the opportunity to exercise full control over the intakes. The operator does not only monitor the functioning of the plant, but can also adjust such parameters as delivery at specific intakes and pump units, by remotely setting the throttle valve opening. Thanks to the wireless data transfer provided by the SATELLINE radio modems, no daily trips are required to get the readings of the water meters installed at the intakes. Another advantage of the system is quicker detection of and faster response to failures.



Manufacturer:

Satel Oy, Meriniitynkatu 17, P.O.Box 142, FIN-24101 Salo
Tel. +358 02 777 7800, fax +358 02 777 7810, E-mail info@satel.fi
www.satel.fi