

SATEL-LP-DO8



I/O extension module, eight digital transistor outputs

Data sheet
106932_en_01

© SATEL

2016-12-07

1 Description

The I/O extension module can be used in conjunction with SATEL-LP wireless modules. In a station structure, you can connect up to 32 I/O extension modules to a wireless module via the DIN rail connector.

The digital I/O extension module is used for processing eight digital signals that are switched using transistor outputs.

Features

- Easy and tool-free I/O mapping via thumb wheel on the front
- Modular design via DIN rail connector (hot-swap capable)
- 8 transistor outputs (30.5 V DC/200 mA)
- DIP switches for Hold or Reset behavior of outputs
- International approvals
- Installation in Ex zone 2



WARNING: Explosion hazard when used in potentially explosive areas

The device is a category 3 item of electrical equipment. Follow the instructions provided here during installation and observe the safety notes.



Make sure you always use the latest documentation.
It can be downloaded from the product at www.satel.com.

SATEL

2	Table of contents	
1	Description	1
2	Table of contents	2
3	Ordering data	3
4	Technical data	3
5	Safety regulations and installation notes.....	6
	5.1 Installation notes	6
	5.2 Installation in Zone 2.....	6
	5.3 UL Notes	6
6	Installation	7
	6.1 Structure	7
	6.2 Basic circuit diagram	7
	6.3 Setting the DIP switches	8
	6.4 Network applications (operating mode)	8
	6.5 I/O MAP address in the SATEL-LP wireless system.....	8
	6.6 Display and diagnostic elements	9
	6.7 Digital outputs	9
	6.8 Mounting and removing.....	10
	6.9 Connecting cables	11
7	Process data.....	12

3 Ordering data

Description	Type	Order No.	Pcs./Pkt.
Digital I/O extension module with 8 digital transistor outputs (30.5 V DC/200 mA), with screw connection, including DIN rail connector	SATEL-LP-DO8	YI0107	1
Accessories	Type	Order No.	Pcs./Pkt.
2400 MHz wireless transceiver with RS-232, RS-485 2-wire interface, expandable with I/O extension modules, with screw connection, antenna connection: RSMA (female), including DIN rail connector, without antenna	SATEL-LP24	YM0424	1
868 MHz wireless transceiver with RS-232, RS-485 2-wire interface, expandable with I/O extension modules, with screw connection, antenna connection: RSMA (female), including DIN rail connector, without antenna.	SATEL-LP8	YM0408	1
Bidirectional, 900 MHz transceiver for wireless transmission of serial and I/O data	SATEL-LP9	YM0409	1
Multipoint multiplexer for RS-485 bus system, can be extended with I/O extension modules. Can be used as Modbus/RTU bus coupler or combined with SATEL-LP wireless system, screw connection. Up to 99 stations, including DIN rail connector	SATEL-LP-RS485	YI0109	1
Digital I/O extension module with 8 digital inputs (0 ... 30.5 V DC) or 2 pulse inputs (0 ... 100 Hz), with screw connection, including DIN rail connector	SATEL-LP-DI8	YI0106	1

4 Technical data

Dimensions	
Dimensions W/H/D	17.5 mm / 99 mm / 114.5 mm
General data	
Overvoltage category	II
Mounting position	any, on standard DIN rail NS 35 in accordance with EN 60715
Degree of protection	IP20
Degree of pollution	2
Type of housing	PA 6.6-FR, black
Flammability rating according to UL 94	V0

General data

MTTF (mean time to failure) Telcordia standard, 25°C temperature, 21% operating cycle (5 days a week, 8 hours a day)	1594 Years
MTTF (mean time to failure) Telcordia standard, 40°C temperature, 34.25% operating cycle (5 days a week, 12 hours a day)	600 Years
MTTF (mean time to failure) Telcordia standard, temperature 40°C, operating cycle 100% (7 days a week, 24 hours a day)	230 Years

Supply

Supply voltage range	19.2 V DC ... 30.5 V DC (DIN rail connector)
Max. current consumption	≤ 22 mA (At 24 V DC, at 25°C)
Transient surge protection	Yes

Transistor output, active

Number of outputs	8
Contact type	Transistor
Maximum switching voltage	30.5 V DC
Minimum switching voltage	12 V DC
Max. switching current	200 mA (per channel)
Supply voltage range	12 V DC ... 30.5 V DC (for digital outputs)
Maximum switching frequency	10 Hz
Behavior of the outputs (adjustable via DIP switch)	Hold / Reset

Electrical isolation

Digital I/O	50 V (Rated insulation voltage (between the channel groups 1...4 and 5...8/TBUS supply, reinforced insulation according to EN 61010))
	300 V (Rated insulation voltage (to adjacent devices, basic insulation in accordance with EN 61010))

Test voltage

Digital I/O	1.5 kV AC (50 Hz, 1 min.)
-------------	---------------------------

Connection data

Connection method	Screw connection
Conductor cross section, solid	0.2 mm ² ... 2.5 mm ²
Conductor cross section, flexible	0.2 mm ² ... 2.5 mm ²
Conductor cross section AWG/kcmil	24 ... 14
Stripping length	7 mm
Tightening torque	0.6 Nm

Status indication

Status display	Green LED (supply voltage, PWR) Green LED (bus communication, DAT) Red LED (periphery error, ERR) Yellow LED (digital output, DO1) Yellow LED (digital output, DO2) Yellow LED (digital output, DO3) Yellow LED (digital output, DO4) Yellow LED (digital output, DO5) Yellow LED (digital output, DO6) Yellow LED (digital output, DO7) Yellow LED (digital output, DO8)
----------------	---

Ambient conditions

Ambient temperature (operation)	-40 °C ... 70 °C -40 °F ... 158 °F
Ambient temperature (storage/transport)	-40 °C ... 85 °C -40 °F ... 185 °F
Permissible humidity (operation)	20 % ... 85 %
Permissible humidity (storage/transport)	20 % ... 85 %
Altitude	2000 m
Vibration (operation)	in accordance with IEC 60068-2-6: 5g, 10 Hz ... 150 Hz
Shock	16g, 11 ms

Certification

Conformance	CE-compliant
ATEX Please follow the special installation instructions in the documentation!	⊕ II 3 G Ex nA IIC T4 Gc (IBExU16ATEXB019 X)
IECEX	Ex nA IIC T4 Gc (IECEX IBE 16.0030X)
UL, USA/Canada	UL 508 Listed Class I, Div. 2, Groups A, B, C, D T4A Class I, Zone 2, IIC T4

Conformance

EMC directive 2014/30/EU	EN 61000-6-2; EN 61000-6-4
Ex directive (ATEX)	EN 60079-0; EN 60079-15

5 Safety regulations and installation notes



WARNING: Risk of electric shock

- Provide a switch/circuit breaker close to the device, which is labeled as the disconnect device for this device or the entire control cabinet.
- Disconnect the device from all power sources during maintenance work and configuration (the device can remain connected to SELV or PELV circuits).
- The housing of the device provides a basic insulation against the neighboring devices, for 300 V eff. If several devices are installed next to each other, this has to be taken into account, and additional insulation has to be installed if necessary. If the neighboring device is equipped with basic insulation, no additional insulation is necessary.

5.1 Installation notes



WARNING:
Observe the following safety notes when using the device.

- The category 3 device is designed for installation in zone 2 potentially explosive areas. It meets the requirements of EN 60079-0:2012+A11:2013 and EN 60079-15:2010.
- Installation, operation, and maintenance may only be carried out by qualified electricians. Follow the installation instructions as described.
- When installing and operating the device, the applicable regulations and safety directives (including national safety directives), as well as general technical regulations, must be observed. The technical data is provided in the package slip and on the certificates (conformity assessment, additional approvals where applicable).
- The device must not be opened or modified. Do not repair the device yourself, replace it with an equivalent device. Repairs may only be carried out by the manufacturer. The manufacturer is not liable for damage resulting from violation.
- The IP20 protection (IEC 60529/EN 60529) of the device is intended for use in a clean and dry environment. The device must not be subject to mechanical strain and/or thermal loads, which exceed the limits described.
- To protect the device against mechanical or electrical damage, install it in a suitable housing with appropriate degree of protection as per IEC 60529.

- The device is not designed for use in atmospheres with a danger of dust explosions.
- If dust is present, it is necessary to install into a suitable approved housing, whereby the surface temperature of the housing must be taken into consideration.

5.2 Installation in Zone 2



WARNING: Explosion hazard when used in potentially explosive areas
Please make sure that the following notes and instructions are observed.

- Observe the specified conditions for use in potentially explosive areas! Install the device in a suitable approved housing (with a minimum of IP54 protection) that meets the requirements of EN 60079-15. Observe the requirements of EN 60079-14.
- In zone 2, only connect devices to the supply and signal circuits that are suitable for operation in the Ex zone 2 and the conditions at the installation location.
- In potentially explosive areas, terminals may only be snapped onto or off the DIN rail connector and wires may only be connected or disconnected when the power is switched off.
- The switches of the device that can be accessed may only be actuated when the power supply to the device is disconnected.
- The device must be stopped and immediately removed from the Ex area if it is damaged, was subject to an impermissible load, stored incorrectly or if it malfunctions.

5.3 UL Notes

INDUSTRIAL CONTROL EQUIPMENT FOR HAZARDOUS LOCATIONS 45FP

- A This equipment is suitable for use in Class I, Zone 2, IIC T4 and Class I, Division 2, Groups A, B, C, D T4A hazardous locations or non-hazardous locations only.
- B **WARNING - EXPLOSION HAZARD - DO NOT DISCONNECT EQUIPMENT UNLESS POWER HAS BEEN SWITCHED OFF OR THE AREA IS KNOWN TO BE NON-HAZARDOUS.**
- C **WARNING - EXPLOSION HAZARD - SUBSTITUTION OF COMPONENTS MAY IMPAIR SUITABILITY FOR CLASS 1, DIVISION 2.**
- D These devices are open-type devices that are to be installed in an enclosure suitable for the environment that is only accessible with the use of a tool.
- E **WARNING - Exposure to some chemicals may degrade the sealing properties of materials used in relays within this device.**

6 Installation



NOTE: electrostatic discharge!

The device contains components that can be damaged or destroyed by electrostatic discharge. When handling the device, observe the necessary safety precautions against electrostatic discharge (ESD) according to EN 61340-5-1 and IEC 61340-5-1.

6.1 Structure

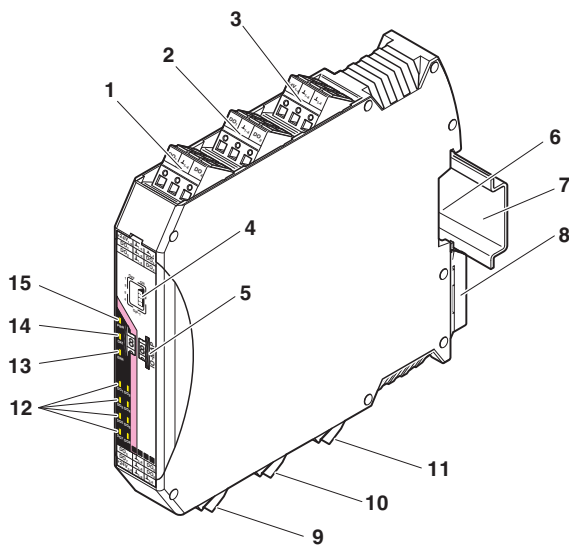

Figure 1 Function elements

Pos.	Designation
1	Transistor outputs 3 + 4
2	Transistor outputs 1 + 2
3	Supply voltage for outputs 1 ... 4
4	DIP switches for configuring the output behavior (hold/reset) of the transistor outputs
5	White thumbwheel for setting the I/O-MAP address
6	Connection option for DIN rail connector
7	DIN rail
8	Metal foot catch for DIN rail fixing
9	Transistor outputs 5 + 6
10	Transistor outputs 7 + 8
11	Supply voltage for outputs 5 ... 8
12	Status LEDs of transistor outputs DO1 ... DO8
13	ERR status LED, red (communication error)
14	DAT status LED, green (bus communication)
15	PWR status LED, green (supply voltage)

6.2 Basic circuit diagram

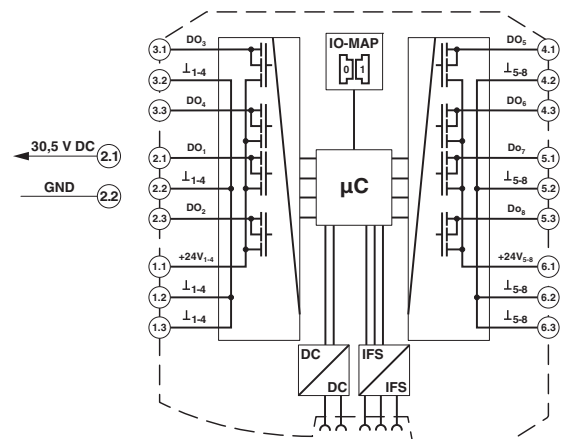

Figure 2 Basic circuit diagram

6.3 Setting the DIP switches

The DIP switches on the front can be used to set the behavior of the outputs in the event of an error (e.g., interruption of the bus communication by interruption of the wireless connection).

For digital outputs DO1 ... DO4 and DO5 ... DO8 you can choose between:

- Reset
- Hold last valid state (Hold)

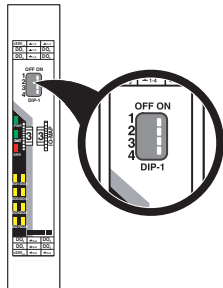

Figure 3 DIP switches

Output	DIP switch				
	Configuration	1	2	3	4
Digital OUT 1 ... 4	Reset	OFF		n. c.	n. c.
Digital OUT 1 ... 4	Hold	ON		n. c.	n. c.
Digital OUT 5 ... 8	Reset		OFF	n. c.	n. c.
Digital OUT 5 ... 8	Hold		ON	n. c.	n. c.

n. c. = not connected, DIP switches 3 + 4 have no function

6.4 Network applications (operating mode)

You can set the network application of the wireless module with the SATEL-LP-CONF software. All SATEL-LP wireless modules are set to I/O data mode (wire in/wire out) by default.

Wireless module in I/O data mode

In an I/O-to-I/O network, only the I/O signals of the connected analog and digital I/O extension modules are transmitted. Assign the inputs and outputs of the extension modules quickly using the white thumbwheel.

In this mode, the serial RS-232 and RS-485 interfaces on the wireless module are deactivated.

Wireless module in PLC/Modbus RTU mode

In PLC/Modbus RTU mode, the wireless master operates as a Modbus slave. The master PLC controls all commands and initiates all data requests.

Input and output data is stored in a Modbus Memory Map in the master wireless module. In this mode, you can access process and diagnostic data for the individual network devices via a Modbus controller.

6.5 I/O MAP address in the SATEL-LP wireless system

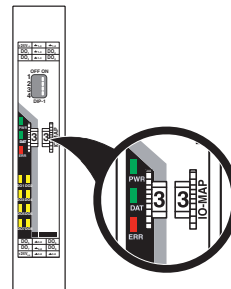

Figure 4 Thumb wheel

Use the thumbwheel to set the I/O-MAP address. The extension module in the SATEL-LP wireless system is addressed using the I/O-MAP address.

Thumbwheel	Description
01 - 99	I/O MAP address
00	Delivery state
** , 1* - 9*	Setting not permitted
*1 - *9	Setting not permitted

Wireless module in I/O data mode

The output device must be provided with the same I/O MAP address as the assigned input device at the other wireless station (I/O mapping).

Output modules with the same I/O MAP address may appear several times in the network at different stations.

Example:	I/O MAP address
SATEL-LP-DO8	02
SATEL-LP-DI8	02

Only the SATEL-LP-DI8 module can be assigned to the SATEL-LP-DO8 module.

Wireless module in PLC/Modbus RTU mode

The I/O MAP address may only appear once in the network. Exception: Output modules with the same I/O MAP address may appear several times in the network at different stations.

The output data is saved in a Modbus memory map in the master wireless module. You can read or write the process data via the serial interface of the master wireless module (RAD-ID = 01) using the Modbus RTU commands (see Section 7).

6.6 Display and diagnostic elements

The I/O extension module uses a total of eleven LEDs to indicate the operating states.

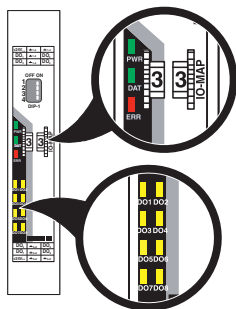

Figure 5 Display and diagnostic elements

PWR LED

The green PWR LED indicates the supply voltage status.

- OFF No supply voltage
- ON Supply voltage OK

DAT LED

The green DAT LED indicates the bus communication status.

- OFF No communication
- Flashing Configuration and addressing mode
- ON Cyclic data communication

ERR LED

The red ERR LED indicates the error status, e.g., no corresponding output module found (e.g., incorrect addressing).

- OFF No error
- Flashing **Wireless module in I/O data mode**
Missing input module, no bus communication
- Wireless module in PLC/Modbus RTU mode**
No Modbus communication, short circuit at one or more outputs
- ON Critical internal error

Digital outputs

The yellow DO1 ... DO8 LEDs indicate the state of the digital outputs.

DO1 ... DO4

- Flashing Short circuit at one output or several outputs 1 ... 4

DO5 ... DO8

- Flashing Short circuit at one output or several outputs 5 ... 8

6.7 Digital outputs

The eight outputs are arranged in two groups of four outputs each with a common electrical supply. The two output groups are electrically isolated from one another, from the supply voltage (via bus foot), and from other electronic components.

The digital outputs must be externally supplied.

Outputs DO1 ... DO4 are supplied using terminals 1.1 and 1.2/1.3.

Outputs DO5 ... DO8 are supplied using terminals 6.1 and 6.2/6.3.

6.8 Mounting and removing

Connection station with I/O extension modules

Up to 32 different I/O extension modules can be connected to every wireless module via the DIN rail connector (see accessories). Data is transmitted and power is supplied to the I/O extension modules via the bus foot.

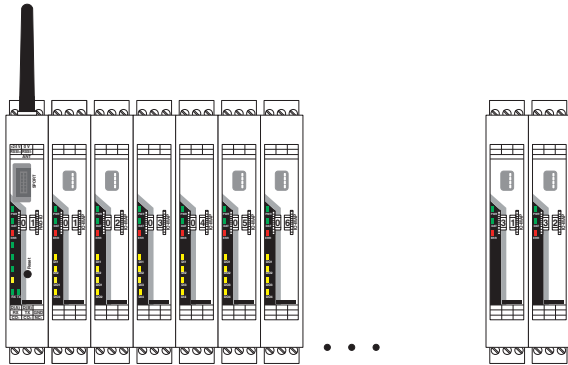

Figure 6 SATEL-LP connection station with up to 32 I/O extension modules



Only mount the I/O extension modules to the right of the wireless module.



Outside the Ex area, module extension or module replacement is also possible during operation.

- Connect the DIN rail connectors together for a connection station.
- Push the connected DIN rail connectors into the DIN rail.
- Place the device onto the DIN rail from above. Ensure the device and DIN rail connector are aligned correctly.
- Holding the device by the housing cover, carefully push the device towards the mounting surface so that the device bus connector is securely fixed onto the DIN rail connector.
- Once the snap-on foot has been audibly snapped onto the DIN rail, check that it is fixed securely. The device is only mechanically secured via the DIN rail.
- Connect the desired number of I/O extension modules to the wireless module via the DIN rail connector.
- In order to meet the requirements for the protection class, install the device in suitable housing.
- During startup, check that the device is operating, wired, and marked correctly.

Assembly

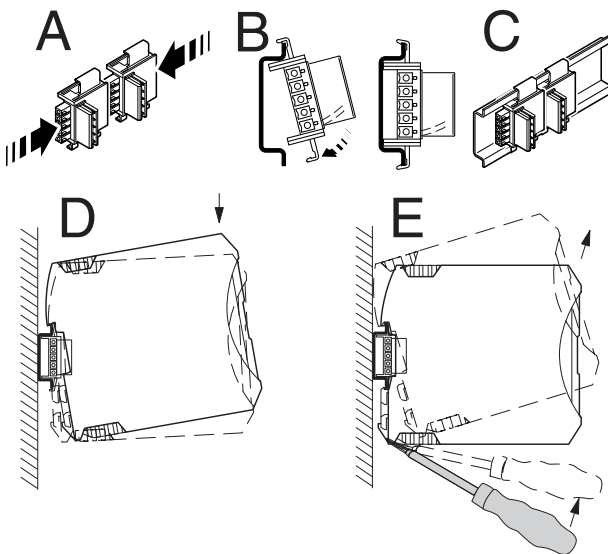

Figure 7 Mounting and removing

Removing

- Use a suitable screwdriver to release the locking mechanism on the snap-on foot of the device.
- Hold onto the device by the housing cover and carefully tilt it upwards.
- Carefully lift the device off the DIN rail connector and the DIN rail.

6.9 Connecting cables

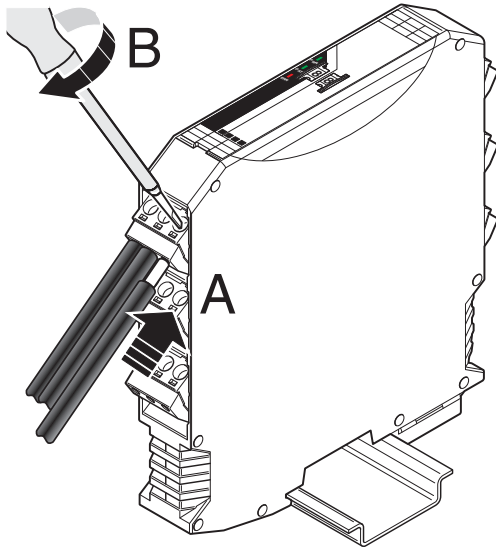

Figure 8 Connecting cables

- Crimp ferrules to the wires.
Permissible cable cross section: 0.2...2.5 mm².
- Insert the wire with ferrule into the corresponding connection terminal block.
- Use a screwdriver to tighten the screw in the opening above the connection terminal block.
Tightening torque: 0.6 Nm

7 Process data

You can read or write the process data via the serial interface of the master wireless module (RAD ID = 01) using Modbus RTU commands.

With the SATEL-LP-CONF software, you can set the wireless module's network application to "PLC/Modbus RTU mode".

I/O module	SATEL-LP-DO8	SATEL-LP-DO8
Module type	11 _{hex}	11 _{hex}
Number of registers	02 _{hex} Outputs	02 _{hex} Short-circuit detection
Address space	40xx0 ... 40xx1	30xx0 ... 30xx1
Modbus function code	fc 03, 16	fc04

xx = I/O MAP address set using the white thumbwheel

30xx0, 40xx0	Module type and currentness of data															
	15	14	13	12	11	10	09	08	07	06	05	04	03	02	01	00
								Y	Module type							

Register values:

Module type If the module type in the register is invalid or unavailable, then the register value is 0

Currentness of data Y = Currentness of data, bit 8

If the data in the register is not up-to-date, then the register value is 1.

If process data has been written to one of the registers, bit 8 in 40xx0 is set to 0. The value in register 40xx0 then remains 0 for the entire operating time of the device.

However, in register 30xx0 bit 8 is reset to 1 as soon as the status of short-circuit detection is not up-to-date.

This is the case, for example, if the wireless connection or communication with an input module fails. In this case, the IN process data is retained in the Modbus table, but is no longer updated.

30xx1	Short-circuit detection at the digital outputs															
	15	14	13	12	11	10	09	08	07	06	05	04	03	02	01	00
	Reserved														X	X

Bit 0 = 1: short circuit at one output or several outputs 1 ... 4

Bit 1 = 1: short circuit at one output or several outputs 5 ... 8

30xx2 ... 30xx9	Reserved
-----------------	----------

40xx1	Digital outputs																
	15	14	13	12	11	10	09	08	07	06	05	04	03	02	01	00	
	Reserved									DO	DO	DO	DO	DO	DO	DO	DO
										8	7	6	5	4	3	2	1
	Terminal point																
										5.x	4.x	3.x	2.x				

40xx2 ... 40xx9	Reserved
-----------------	----------