

# SATEL-LP-DOR4

## I/O extension module, 4 digital relay outputs

Data sheet  
106922\_en\_01

© Satel

2016-12-07



### 1 Description

The I/O extension module can be used in conjunction with SATEL-LP wireless modules. In a station structure, you can connect up to 32 I/O extension modules to a wireless module via the DIN rail connector.

The digital I/O extension module is used for processing four switching signals that are switched via relay outputs. Signals are forwarded for each switching signal via a floating N/C/N/O contact.

#### Features

- Easy and tool-free I/O mapping via thumb wheel on the front
- Modular design via DIN rail connector (hot-swap capable)
- Channel-to-channel electrical isolation
- 4 relay outputs (24 V DC / 250 V AC / 5 A)
- DIP switches for Hold or Reset behavior of outputs
- International approvals
- Installation in Ex zone 2



**WARNING: Explosion hazard when used in potentially explosive areas**

The device is a category 3 item of electrical equipment. Follow the instructions provided here during installation and observe the safety notes.



Make sure you always use the latest documentation.  
It can be downloaded from the product at [www.satel.com](http://www.satel.com).

**SATEL**

---

<b>2</b>	<b>Table of contents</b>	
1	Description .....	1
2	Table of contents .....	2
3	Ordering data .....	3
4	Technical data .....	4
5	Safety regulations and installation notes.....	7
5.1	Installation notes .....	7
5.2	Installation in Zone 2.....	8
5.3	UL Notes .....	8
6	Installation .....	9
6.1	Structure .....	9
6.2	Basic circuit diagram .....	9
6.3	Configuration .....	10
6.4	I/O MAP address in the SATEL-LP wireless system.....	10
6.5	Display and diagnostic elements .....	11
6.6	Digital outputs .....	11
6.7	Mounting and removing.....	12
6.8	Connecting cables .....	13
7	Process data.....	14

### 3 Ordering data

Description	Type	Order No.	Pcs./Pkt.
Digital I/O extension module with 4 digital relay outputs (5 A, 250 V AC/ 24 V DC), with screw connection, incl. DIN rail connector	SATEL-LP-DOR4	YI0102	1
Accessories	Type	Order No.	Pcs./Pkt.
2400 MHz wireless transceiver with RS-232, RS-485 2-wire interface, expandable with I/O extension modules, with screw connection, antenna connection: RSMA (female), including DIN rail connector, without antenna	SATEL-LP24	YM0424	1
868 MHz wireless transceiver with RS-232, RS-485 2-wire interface, expandable with I/O extension modules, with screw connection, antenna connection: RSMA (female), including DIN rail connector, without antenna.	SATEL-LP8	YM0408	1
Bidirectional, 900 MHz transceiver for wireless transmission of serial and I/O data	SATEL-LP9	YM0409	1
Multipoint multiplexer for RS-485 bus system, can be extended with I/O extension modules. Can be used as Modbus/RTU bus coupler or combined with SATEL-LP wireless system, screw connection. Up to 99 stations, including DIN rail connector	SATEL-LP-RS485	YI0109	1
Digital I/O extension module with 4 digital inputs (0...250 V AC/DC), with screw connection, incl. DIN rail connector	SATEL-LP-DI4	YI0101	1

## 4 Technical data

<b>Dimensions</b>	
Dimensions W/H/D	17.5 mm / 99 mm / 114.5 mm
<b>General data</b>	
Overvoltage category	II
Mounting position	any, on standard DIN rail NS 35 in accordance with EN 60715
Degree of protection	IP20
Degree of pollution	2
Type of housing	PA 6.6-FR, black
Flammability rating according to UL 94	V0
MTTF (mean time to failure) Telcordia standard, 25°C temperature, 21% operating cycle (5 days a week, 8 hours a day)	1087 Years
MTTF (mean time to failure) Telcordia standard, 40°C temperature, 34.25% operating cycle (5 days a week, 12 hours a day)	523 Years
MTTF (mean time to failure) Telcordia standard, temperature 40°C, operating cycle 100% (7 days a week, 24 hours a day)	204 Years
<b>Supply</b>	
Supply voltage range	19.2 V DC ... 30.5 V DC (DIN rail connector)
Max. current consumption	≤ 55 mA (At 24 V DC, at 25°C)
Transient surge protection	Yes
<b>Relay output</b>	
Number of outputs	4
Contact type	PDT
Contact material	AgSnO <sub>2</sub>
Maximum switching voltage	250 V AC 24 V DC
Min. switching current	≥ 10 mA
Max. switching current	5 A (per channel)
Mechanical service life	1 x 10 <sup>7</sup> cycles
Electrical service life	1 x 10 <sup>5</sup> cycles (At 5 A, 250 V AC, ohmic) 2 x 10 <sup>5</sup> cycles (At 2 A, 250 V AC, cosφ 0.4) 2 x 10 <sup>5</sup> cycles (At 1 A, 24 V DC, L/R = 48 ms)

**Relay output**

Maximum switching frequency	2 Hz
Switching capacity	140 W (24 V DC) 120 W (30 V DC) 20 W (48 V DC) 18 W (60 V DC) 22 W (110 V DC) 40 W (220 V DC) 42 W (250 V DC) 1500 VA
Behavior of the outputs (adjustable via DIP switch)	Hold / Reset

**Electrical isolation**

Digital I/O	300 V (Rated insulation voltage (in each case between the digital outputs // TBUS supply, reinforced insulation according to EN 61010))
	300 V (Rated insulation voltage (to adjacent devices, basic insulation in accordance with EN 61010))

**Test voltage**

Digital I/O	2.5 kV AC (50 Hz, 1 min.)
-------------	---------------------------

**Connection data**

Connection method	Screw connection
Conductor cross section, solid	0.2 mm <sup>2</sup> ... 2.5 mm <sup>2</sup>
Conductor cross section, flexible	0.2 mm <sup>2</sup> ... 2.5 mm <sup>2</sup>
Conductor cross section AWG/kcmil	24 ... 14
Stripping length	7 mm
Tightening torque	0.6 Nm

**Status indication**

Status display	Green LED (supply voltage, PWR) Green LED (bus communication, DAT) Red LED (periphery error, ERR) Yellow LED (digital output, DO1) Yellow LED (digital output, DO2) Yellow LED (digital output, DO3) Yellow LED (digital output, DO4)
----------------	---

**Ambient conditions**

Ambient temperature (operation)	-40 °C ... 70 °C (>55°C derating) -40 °F ... 158 °F (>131°F derating)
Ambient temperature (storage/transport)	-40 °C ... 85 °C -40 °F ... 185 °F
Permissible humidity (operation)	20 % ... 85 %
Permissible humidity (storage/transport)	20 % ... 85 %
Altitude	2000 m
Vibration (operation)	in accordance with IEC 60068-2-6: 5g, 10 Hz ... 150 Hz
Shock	16g, 11 ms

**Operating conditions for the extended temperature range (+55 °C ... 70 °C)**



No function restrictions for the extended temperature range if you observe a minimum spacing of 17.5 mm between the modules. The minimum spacing is the width of a DIN rail connector.  
 Otherwise please observe the following restrictions:  
 – Maximum switching current of 1 A per channel  
 Individual operating conditions available on request.

**Certification**

Conformance	CE-compliant
ATEX Please follow the special installation instructions in the documentation!	Ⓔ II 3 G Ex nA nC IIC T4 Gc (IBExU16ATEXB019 X)
IECEX	Ex nA nC IIC T4 Gc (IECEX IBE 16.0030X)
UL, USA/Canada	UL 508 Listed Class I, Div. 2, Groups A, B, C, D T4A Class I, Zone 2, IIC T4

**Conformance**

EMC directive 2014/30/EU	EN 61000-6-2; EN 61000-6-4
Ex directive (ATEX)	EN 60079-0; EN 60079-15

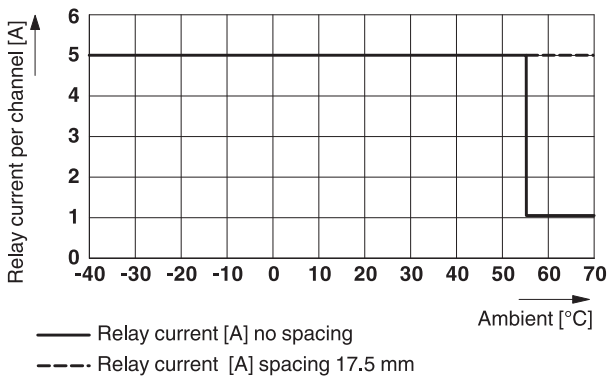

Figure 1 Derating the digital outputs

## 5 Safety regulations and installation notes



### **WARNING: Risk of electric shock**

During operation, certain parts of this device may carry hazardous voltages. Disregarding this warning may result in damage to equipment and/or serious personal injury.

- For applications with high operating voltages, ensure sufficient distance or insulation and provide shock protection.
- Provide a switch/circuit breaker close to the device, which is labeled as the disconnect device for this device or the entire control cabinet.
- Disconnect the device from all power sources during maintenance work and configuration (the device can remain connected to SELV or PELV circuits).
- The housing of the device provides a basic insulation against the neighboring devices, for 300 V eff. If several devices are installed next to each other, this has to be taken into account, and additional insulation has to be installed if necessary. If the neighboring device is equipped with basic insulation, no additional insulation is necessary.

### 5.1 Installation notes



#### **WARNING:**

Observe the following safety notes when using the device.

- The category 3 device is designed for installation in zone 2 potentially explosive areas. It meets the requirements of EN 60079-0:2012+A11:2013 and EN 60079-15:2010.
- Installation, operation, and maintenance may only be carried out by qualified electricians. Follow the installation instructions as described.
- When installing and operating the device, the applicable regulations and safety directives (including national safety directives), as well as general technical regulations, must be observed. The technical data is provided in the package slip and on the certificates (conformity assessment, additional approvals where applicable).
- The device must not be opened or modified. Do not repair the device yourself, replace it with an equivalent device. Repairs may only be carried out by the manufacturer. The manufacturer is not liable for damage resulting from violation.
- The IP20 protection (IEC 60529/EN 60529) of the device is intended for use in a clean and dry environment. The device must not be subject to mechanical strain and/or thermal loads, which exceed the limits described.
- To protect the device against mechanical or electrical damage, install it in a suitable housing with appropriate degree of protection as per IEC 60529.
- The device is not designed for use in atmospheres with a danger of dust explosions.
- If dust is present, it is necessary to install into a suitable approved housing, whereby the surface temperature of the housing must be taken into consideration.

## 5.2 Installation in Zone 2

**WARNING: Explosion hazard when used in potentially explosive areas**

Please make sure that the following notes and instructions are observed.

- Observe the specified conditions for use in potentially explosive areas! Install the device in a suitable approved housing (with a minimum of IP54 protection) that meets the requirements of EN 60079-15. Observe the requirements of EN 60079-14.
- In zone 2, only connect devices to the supply and signal circuits that are suitable for operation in the Ex zone 2 and the conditions at the installation location.
- In potentially explosive areas, terminals may only be snapped onto or off the DIN rail connector and wires may only be connected or disconnected when the power is switched off.
- The switches of the device that can be accessed may only be actuated when the power supply to the device is disconnected.
- The device must be stopped and immediately removed from the Ex area if it is damaged, was subject to an impermissible load, stored incorrectly or if it malfunctions.

## 5.3 UL Notes

**INDUSTRIAL CONTROL EQUIPMENT FOR HAZARDOUS LOCATIONS 45FP**

- A This equipment is suitable for use in Class I, Zone 2, IIC T4 and Class I, Division 2, Groups A, B, C,D T4A hazardous locations or non-hazardous locations only.
- B **WARNING - EXPLOSION HAZARD - DO NOT DISCONNECT EQUIPMENT UNLESS POWER HAS BEEN SWITCHED OFF OR THE AREA IS KNOWN TO BE NON-HAZARDOUS.**
- C **WARNING - EXPLOSION HAZARD - SUBSTITUTION OF COMPONENTS MAY IMPAIR SUITABILITY FOR CLASS 1, DIVISION 2.**
- D These devices are open-type devices that are to be installed in an enclosure suitable for the environment that is only accessible with the use of a tool.
- E **WARNING - Exposure to some chemicals may degrade the sealing properties of materials used in relays within this device.**



## 6 Installation



**NOTE: electrostatic discharge!**

The device contains components that can be damaged or destroyed by electrostatic discharge. When handling the device, observe the necessary safety precautions against electrostatic discharge (ESD) according to EN 61340-5-1 and IEC 61340-5-1.

### 6.1 Structure

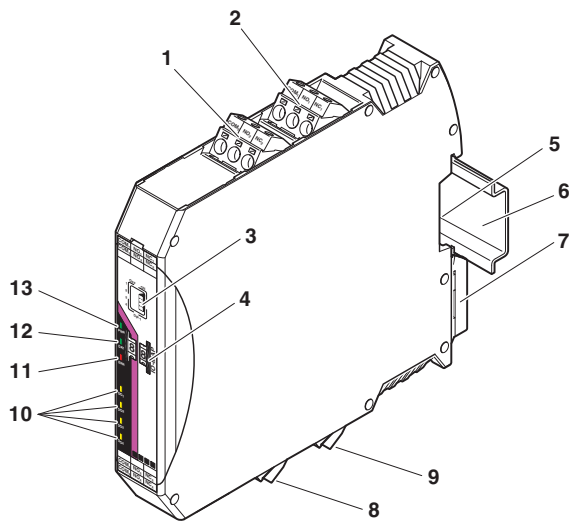

Figure 2 Function elements

Pos.	Designation
1	Relay output 2 with PDT contact (floating)
2	Relay output 1 with PDT contact (floating)
3	DIP switches for configuring the output behavior (hold/reset) of the relay outputs
4	White thumbwheel for setting the I/O-MAP address
5	Connection option for DIN rail connector
6	DIN rail
7	Metal foot catch for DIN rail fixing
8	Relay output 3 with PDT contact (floating)
9	Relay output 4 with PDT contact (floating)
10	Status LEDs for the relay outputs DO1...DO4
11	ERR status LED, red (communication error)
12	DAT status LED, green (BUS communication)
13	PWR status LED, green (supply voltage)

### 6.2 Basic circuit diagram

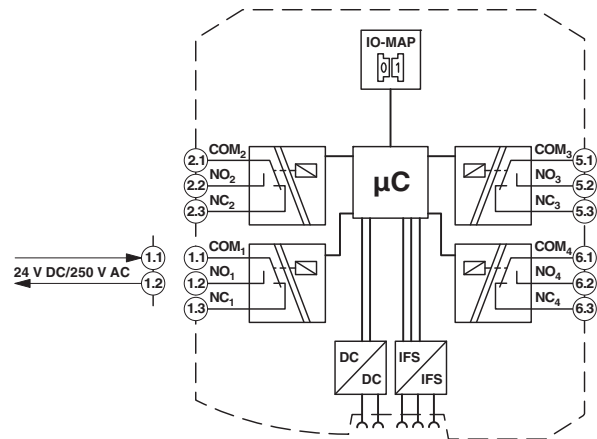

Figure 3 Basic circuit diagram

### 6.3 Configuration

The DIP switches on the front can be used to set the behavior of the outputs in the event of an error (e.g., interruption of the bus communication by interruption of the wireless connection).

For digital outputs DO1 ... DO4 you can select the "reset" option (relay drops out = Reset) or the "hold last valid state" option (Hold).

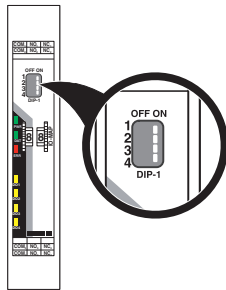

Figure 4 DIP switches

Output	Configuration	DIP switch			
		1	2	3	4
Digital OUT1	Reset	OFF			
Digital OUT1	Hold	ON			
Digital OUT2	Reset		OFF		
Digital OUT2	Hold		ON		
Digital OUT3	Reset			OFF	
Digital OUT3	Hold			ON	
Digital OUT4	Reset				OFF
Digital OUT4	Hold				ON

### 6.4 I/O MAP address in the SATEL-LP wireless system

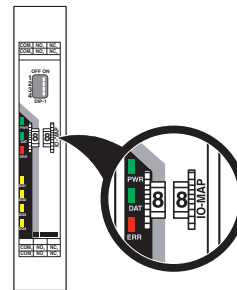

Figure 5 Thumb wheel

Use the thumbwheel to set the I/O-MAP address. The extension module in the SATEL-LP wireless system is addressed using the I/O-MAP address.

On the entire wireless network, addresses 1 to 99 (I/O MAP) (maximum) may be assigned for the I/O extension modules.

Thumbwheel	Description
01 - 99	I/O MAP address
00	Delivery state
** , 1* - 9*	Setting not permitted
*1 - *9	Setting not permitted

**Wireless module in I/O data mode**

The output device must be provided with the same I/O MAP address as the assigned input device at the other wireless station (I/O mapping).

Output modules with the same I/O MAP address may appear several times in the network at different stations.

Example:	I/O MAP address
SATEL-LP-DOR4	02
SATEL-LP-DI4	02

Only the SATEL-LP-DI4 module can be assigned to the SATEL-LP-DOR4 module.

**Wireless module in PLC/Modbus RTU mode**

The I/O MAP address may only appear once in the network. Exception: Output modules with the same I/O MAP address may appear several times in the network at different stations.

The output data is saved in a Modbus memory map in the master wireless module. You can read or write the process data via the serial interface of the master wireless module (RAD-ID = 01) using the Modbus RTU commands (see Section 7).

**6.5 Display and diagnostic elements**

The I/O extension module uses a total of seven LEDs to indicate the operating states.

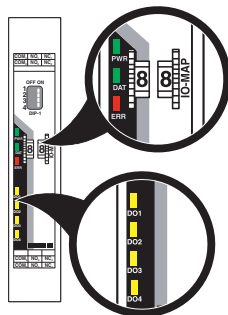

Figure 6 Display and diagnostic elements

**PWR LED**

The green PWR LED indicates the supply voltage status.

- OFF No supply voltage
- ON Supply voltage OK

**DAT LED**

The green DAT LED indicates the bus communication status.

- OFF No communication
- Flashing Configuration and addressing mode
- ON Cyclic data communication

**ERR LED**

The red ERR LED indicates the error status, e.g., no corresponding output module found (e.g., incorrect addressing).

- OFF No error
- Flashing Slow (1.4 Hz) I/O-MAP address changed
- Fast (2.8 Hz) **Wireless module in I/O data mode**

Missing input module, no bus communication

**Wireless module in PLC/Modbus RTU mode**

No Modbus communication (safe state of outputs, depending on DIP switch setting)

- ON Critical internal error

**DO1 ... DO4**

The yellow DO1 ... DO4 LEDs indicate the status of the digital outputs.

**6.6 Digital outputs**

The digital outputs of the extension module (1, 2, 8, 9 in Figure 2) are designed as floating relay contacts (PDT).

The digital outputs are electrically isolated (reinforced insulation) from one another, from the supply voltage (via the bus foot), and from other electronic components.

## 6.7 Mounting and removing

### Connection station with I/O extension modules

Up to 32 different I/O extension modules can be connected to every wireless module via the DIN rail connector (see accessories). Data is transmitted and power is supplied to the I/O extension modules via the bus foot.

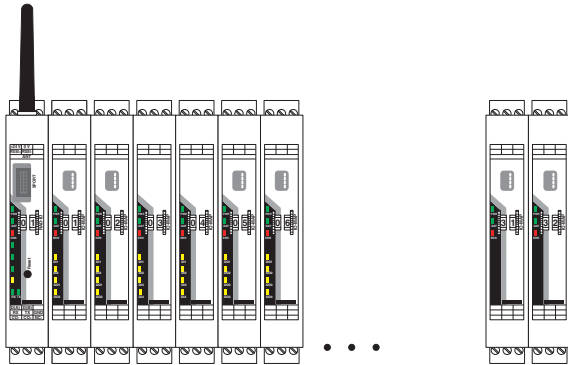

Figure 7 SATEL-LP connection station with up to 32 I/O extension modules



Only mount the I/O extension modules to the right of the wireless module.

### Assembly

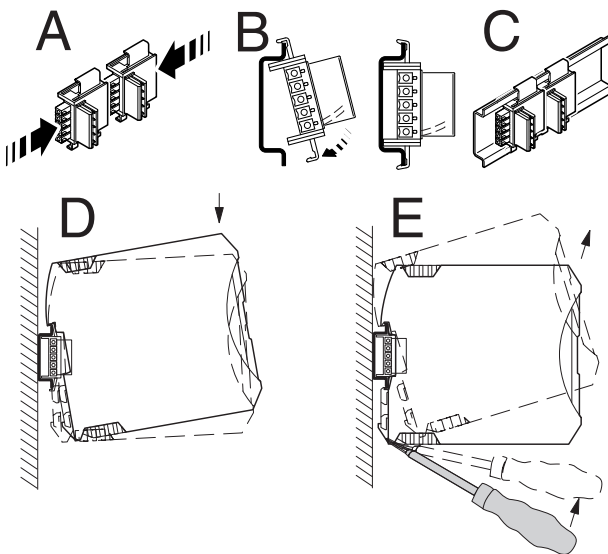

Figure 8 Mounting and removing

When using the device in a connection station, use the 17.5 mm wide DIN rail connector supplied. Only use the DIN rail connector in connection with 24 V DC devices.



Outside the Ex area, module extension or module replacement is also possible during operation.

- Connect the DIN rail connectors together for a connection station.
- Push the connected DIN rail connectors into the DIN rail.
- Place the device onto the DIN rail from above. Ensure the device and DIN rail connector are aligned correctly.
- Holding the device by the housing cover, carefully push the device towards the mounting surface so that the device bus connector is securely fixed onto the DIN rail connector.
- Once the snap-on foot has been audibly snapped onto the DIN rail, check that it is fixed securely. The device is only mechanically secured via the DIN rail.
- Connect the desired number of I/O extension modules to the wireless module via the DIN rail connector.
- In order to meet the requirements for the protection class, install the device in suitable housing.
- During startup, check that the device is operating, wired, and marked correctly.

### Removing

- Use a suitable screwdriver to release the locking mechanism on the snap-on foot of the device.
- Hold onto the device by the housing cover and carefully tilt it upwards.
- Carefully lift the device off the DIN rail connector and the DIN rail.

## 6.8 Connecting cables

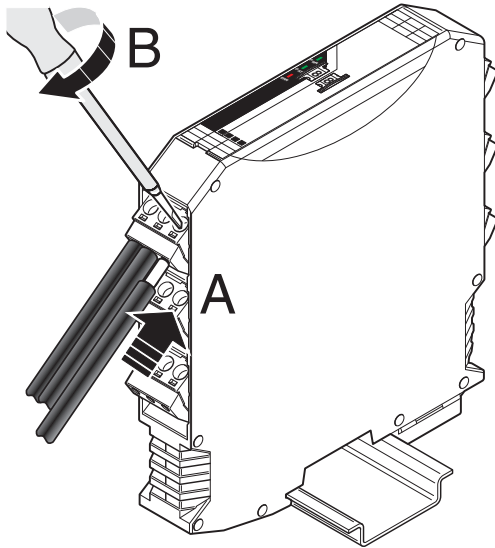

Figure 9 Connecting cables

- Crimp ferrules to the wires.  
Permissible cable cross section: 0.2...2.5 mm<sup>2</sup>.
- Insert the wire with ferrule into the corresponding connection terminal block.
- Use a screwdriver to tighten the screw in the opening above the connection terminal block.  
Tightening torque: 0.6 Nm

## 7 Process data

You can read or write the process data via the serial interface of the master wireless module (RAD ID = 01) using Modbus RTU commands.

With the SATEL-LP-CONF software, you can set the wireless module's network application to "PLC/Modbus RTU mode".

<b>I/O module</b>	<b>SATEL-LP-DOR4</b>
Module type	10 <sub>hex</sub>
Number of registers	02 <sub>hex</sub>
Address space	40xx0 ... 40xx1
Modbus function code	fc 03, 16

xx = I/O MAP address set using the white thumbwheel

40xx0		Module type and currentness of data																
15	14	13	12	11	10	09	08	07	06	05	04	03	02	01	00			
								Y	Module type									

### Register values:

Module type If the module type in the register is invalid or unavailable, then the register value is 0

Currentness of data Y = Currentness of data, bit 8  
If the data in the register is not up-to-date, then the register value is 1.

If process data has been written to one of the registers, the register value = 0.  
The register value then remains 0 for the entire operating time of the device.

40xx1		Digital outputs																	
15	14	13	12	11	10	09	08	07	06	05	04	03	02	01	00				
												DO	DO	DO	DO				
												4	3	2	1				
Terminal point																			
																6.x	5.x	2.x	1.x

<b>40xx2 ... 40xx9</b>	<b>Reserved</b>
------------------------	-----------------