

SATEL

Mission-Critical Connectivity

SATEL-TR300 TRANSCEIVER MODULE

INTEGRATION GUIDE

Version 1.2

IMPORTANT NOTICE

All rights to this manual are owned solely by SATEL Oy (referred to in this user guide as SATEL). All rights reserved. The copying of this manual (without the written permission from the owner) by printing, copying, recording or by any other means, or the full or partial translation of the manual to any other language, including all programming languages, using any electrical, mechanical, magnetic, optical, manual or other methods or devices is forbidden.

SATEL reserves the right to change the technical specifications or functions of its products, or to discontinue the manufacture of any of its products or to discontinue the support of any of its products, without any written announcement and urges its customers to ensure, that the information at their disposal is valid.

SATEL software and programs are delivered "as is". The manufacturer does not grant any kind of warranty including guarantees on suitability and applicability to a certain application. Under no circumstances is the manufacturer or the developer of a program responsible for any possible damages caused by the use of a program. The names of the programs as well as all copyrights relating to the programs are the sole property of SATEL. Any transfer, licensing to a third party, leasing, renting, transportation, copying, editing, translating, modifying into another programming language or reverse engineering for any intent is forbidden without the written consent of SATEL.

SATEL PRODUCTS HAVE NOT BEEN DESIGNED, INTENDED NOR INSPECTED TO BE USED IN ANY LIFE SUPPORT RELATED DEVICE OR SYSTEM RELATED FUNCTION NOR AS A PART OF ANY OTHER CRITICAL SYSTEM AND ARE GRANTED NO FUNCTIONAL WARRANTY IF THEY ARE USED IN ANY OF THE APPLICATIONS MENTIONED.

Salou, FINLAND 2025

RESTRICTIONS ON USE – SATEL-TR300

SATEL-TR300 radio transceiver module has been designed to operate on 320-380 MHz, the exact use of which differs from one region and/or country to another. The user of a radio transceiver module must take care that the said device is not operated without the permission of the local authorities on frequencies other than those specifically reserved and intended for use without a specific permit.

SATEL-TR300 is allowed to be used in the following countries. More detailed information is available at the local frequency management authority.

AE, AT, AU, BE, BG, CH, CY, CZ, DE, DK, EE, ES, FI, FR, GB, GR, HU, HR, IE, IS, IT, JP, KR, LT, LU, LV, MT, NL, NO, PL, PT, RO, SE, SI, SK

Countries: JP (see sections: Host integration and 6.1 Japan regional specific features)

WARNING – RF Exposure! To comply with RF exposure compliance requirements in Europe, maximum antenna gain is 12 dBi and a separation distance listed in a table below must be maintained between the antenna of this device and all persons.

Antenna Gain [dBi]	Separation distance [cm]
0	23
4	36
6	45
8	56
10	71
12	89

This integration guide applies to the combination of Firmware / Hardware version listed in the table below. See www.satel.com for the newest Integration Guide version.

Firmware version	Hardware version
07.71.2.5.xx.xx	SPL0091a
07.72.2.5.xx.xx	SPL0091a

PRODUCT CONFORMITY

Under the sole responsibility of manufacturer SATEL Oy declares that SATEL-TR300 radio transceiver module is in compliance with the essential requirements (radio performance, electromagnetic compatibility and electrical safety) and other relevant provisions of Directives 2014/53/EU and 2011/65/EU and Council recommendation 1999/519/EC. Therefore, the equipment is labeled with the following CE-marking. The operating frequency range of the device is not harmonized throughout the market area, and the local spectrum authority should be contacted before the usage of the radio module.



WARRANTY AND SAFETY INSTRUCTIONS

Read these safety instructions carefully before using the product:

-Warranty will be void, if the product is used in any way that is in contradiction with the instructions given in this manual

-The radio transceiver module is only to be operated at frequencies allocated by local authorities, and without exceeding the given maximum allowed output power ratings. SATEL and its distributors are not responsible, if any products manufactured by it are used in unlawful ways.

-The devices mentioned in this manual are to be used only according to the instructions described in this manual. Faultless and safe operation of the devices can be guaranteed only if the transport, storage, operation and handling of the device are appropriate. This also applies to the maintenance of the products.

HOST INTEGRATION

To ensure compliance with all non-transmitter functions the host manufacturer is responsible for ensuring compliance with the module(s) installed and fully operational.

Japan certification:

SATEL-TR300 meets the applicable requirements of Article 2-1-4-6 Convenience radio requirements:

- 6.25 kHz channel width
- Transmission time restriction
- Carrier sensing function
- Call name storage device ID

SATEL-TR300 is technically pre-certified and ready to be integrated into the final product.

The final product must be certified for the Japanese market (contact SATEL Oy for more information).

TABLE OF CONTENTS

1	INTRODUCTION	9
1.1	Terms and abbreviations	9
1.2	Description of the product	9
2	TECHNICAL SPECIFICATIONS.....	10
2.1	Absolute maximum ratings	10
2.2	DC electrical specifications	10
2.3	Specifications, SATEL-TR300.....	11
3	TIME PARAMETERS FOR STARTUP AND SHUTDOWN SEQUENCES.....	14
3.1	Startup sequence.....	14
3.2	Shutdown and ENA sequences	15
4	ELECTRICAL INTERCONNECTION	16
4.1	DTE connector	16
4.2	Pin order of the DTE connector.....	17
4.3	Equivalent I/O Schematics	18
4.4	RF interface.....	19
4.5	VCC_IO pin.....	20
4.6	Service pin	20
4.7	Stat pin	20
4.8	VCC pins	21
4.9	UART pins.....	21
4.10	GPIO pins	21
5	MECHANICAL CONSIDERATIONS	22

- 5.1 Fixing device to host22**
- 5.2 Heat transfer22**

- 6 OPERATING MODES23**
- 6.1 Japan regional specific features23**
- 6.2 Safe mode24**
- 6.3 Power up / power down scenarios24**
- 6.4 Sleep Mode25**
- 6.5 Power Save Mode25**
- 6.6 Restart26**

- 7 CONFIGURATION27**
- 7.1 SATEL NETCO DEVICE software27**
- 7.2 SATEL Configuration Manager software27**
- 7.3 Changing parameters using SL commands28**
 - 7.3.1 SL Commands 28
 - 7.3.2 SL Command Mode 29

- 8 SERIAL INTERFACE30**
- 8.1 Pause length30**
- 8.2 Data buffering31**

- 9 RADIO PARAMETERS32**
- 9.1 Transmitter32**
- 9.2 Receiver32**
- 9.3 Encryption33**
- 9.4 Radio state34**
- 9.5 Priority RX/TX34**
- 9.6 Forward Error Correction (FEC)34**

- 9.7 Error checking35**
- 9.8 TX Delay35**
- 9.9 Add RSSI to data36**
- 9.10 Separate TX/RX frequencies.....36**
- 9.11 User data whitening.....36**
- 9.12 Channel list36**
- 9.13 Repeater -mode38**
- 10 TEST MODES.....39**
- 10.1 Short Block Test.....39**
- 10.2 Long Block Test39**
- 11 DEFAULT DELIVERY VALUES40**
- 12 CONSIDERATIONS41**
- 12.1 EMI Interferers.....41**
- 12.2 Electrostatic discharge.....42**
- 12.3 Using the device in unmanned high reliability applications42**
- 12.4 Proposals for more reliable radio link.....43**
- 13 APPENDIX44**
- 13.1 Module dimensions44**
- 14 VERSION HISTORY.....45**

1 INTRODUCTION

SATEL – the world’s leading expert and innovator in wireless networking technology. We design, manufacture and offer high quality connectivity solutions that enable secure, mission-critical connections, utilizing the best characteristics of each technology for real-life use-cases.

This document is the integration guide for the SATEL-TR300 radio transceiver module. It is intended to describe how to use these modules and how to integrate those into a host device.

1.1 Terms and abbreviations

Abbreviation	Description
CTS	Clear To Send, handshaking signal used in asynchronous communication.
DTE	Data Terminal Equipment (typically computer, terminal...)
ESD	Electrostatic discharge
RD	Receive Data
TD	Transmit Data
RTS	Ready To Send, handshaking signal used in asynchronous communication.
RAM	Random Access Memory
LDO	Low dropout regulator
UHF	Ultra High Frequency
RF	Radio Frequency
CPU	Central processing unit

1.2 Description of the product

The SATEL-TR300 is a UHF radio transceiver module, which transmits and receives data from the UHF frequency band. The module is designed to be as compact and power efficient as possible. It has been developed to be especially suitable for integration into battery powered and space constrained host applications benefiting from UHF communications.

The transceiver module transmits and receives data via the Air interface, modulates and demodulates, encodes and decodes the data and sends the received data payload to the DTE port. The DTE interface is used to provide power and communicate with the module.

2 TECHNICAL SPECIFICATIONS

2.1 Absolute maximum ratings

Absolute maximum ratings for voltages on different pins are listed in the following table. Exceeding these values will cause permanent damage to the module.

Parameter	Min	Max
Voltage at VCC_IN	0 V	+6 V
Voltage at ENA_MOD	0 V	+6 V
Voltage at VCC_IO	0 V	3.75 V
Voltage at digital inputs (except ENA_MOD)	0 V	3.75 V
Voltage at digital outputs	0 V	3.75 V

Note. All voltages are referenced to GND.

2.2 DC electrical specifications

Recommended operating conditions:

Parameter	Condition	Min	Max	Units
VCC_IN		+3.8	+5.5	V
ENA_MOD, Vlow		0	0.2	V
ENA_MOD, Vhigh		1.2	VCC_IN	V
VCC_IO		1.8	3.3	V
Logic input, Vlow	1.8 V < VCC_IO < 3.3V	0	0.3	V
Logic input, Vhigh	1.8 V < VCC_IO < 3.3V	0.9*VCC_IO	VCCIO	V
Logic output, Vlow	1.8 V < VCC_IO < 3.3V	0	0.5	V
Logic output, Vhigh	1.8 V < VCC_IO < 3.3V	0.6*VCC_IO	VCCIO	V
Logic output, max current	All logic output except STAT pin.	-	4	mA
Logic output, max current, STAT pin		-	12	mA

2.3 Specifications, SATEL-TR300

SATEL-TR300 complies with the following international standards:

EN 300 113 V2.2.1 (4FSK FEC ON and 8FSK FEC ON)

EN 301 489-1

EN 300 166 V2.1.1

IEC 62368-1

	RECEIVER	TRANSMITTER	Note!
Frequency Range	320 ... 380 MHz		
Tuning range	60 MHz		
Minimum RF Frequency Step	6.25 kHz		10 kHz @ 20 kHz channel spacing
Channel Bandwidth	6.25, 12.5, 20 (uses 12.5kHz channel width), 25 kHz		
Frequency Stability	±0.5 ppm		-40°C...+85°C (Reference to +25°C)
Maximum Receiver Input Power without Damage	+3 dBm		
Maximum Receiver Input Power without Transmission Errors	-10 dBm		4FSK, 25 kHz, FEC ON
Sensitivity ¹ BER = 10 ⁻²	typ. -113 dBm		4FSK, 25 kHz, FEC ON
	typ. -115 dBm		4FSK, 12.5 kHz, FEC ON
	typ. -112 dBm		8FSK, 25 kHz, FEC ON
	typ. -113 dBm		8FSK, 12.5 kHz, FEC ON
	typ. -104 dBm		16FSK, 25 kHz, FEC ON
	typ. -106 dBm		16FSK, 12.5 kHz, FEC ON
Blocking ¹ BER = 10 ⁻²	typ. -17 dBm		4FSK, 25 kHz, FEC ON
	typ. -18 dBm		4FSK, 12.5 kHz, FEC ON
	typ. -18 dBm		8FSK, 25 kHz, FEC ON
	typ. -17 dBm		8FSK, 12.5 kHz, FEC ON
	typ. -29 dBm		16FSK, 25 kHz, FEC ON
	typ. -25 dBm		16FSK, 12.5 kHz, FEC ON
Intermodulation Response Rejection ¹ BER = 10 ⁻²	typ. -37 dBm		4FSK, 25 kHz, FEC ON
	typ. -39 dBm		4FSK, 12.5 kHz, FEC ON
	typ. -36 dBm		8FSK, 25 kHz, FEC ON
	typ. -36 dBm		8FSK, 12.5 kHz, FEC ON
	typ. -44 dBm		16FSK, 25 kHz, FEC ON
	typ. -41 dBm		16FSK, 12.5 kHz, FEC ON
CO-Channel Rejection ¹ BER = 10 ⁻²	typ. 8 dB		4FSK, 25 kHz, FEC ON
	typ. 11 dB		4FSK, 12.5 kHz, FEC ON
	typ. 10 dB		8FSK, 25 kHz, FEC ON
	typ. 11 dB		8FSK, 12.5 kHz, FEC ON
	typ. 21 dB		16FSK, 25 kHz, FEC ON
	typ. 20 dB		16FSK, 12.5 kHz, FEC ON
	typ. -33 dBm		4FSK, 25 kHz, FEC ON

Adjacent Channel Selectivity ¹ BER = 10 ⁻²	typ. -45 dBm		4FSK, 12.5 kHz, FEC ON
	typ. -34 dBm		8FSK, 25 kHz, FEC ON
	typ. -34 dBm		8FSK, 12.5 kHz, FEC ON
	typ. -43 dBm		16FSK, 25 kHz, FEC ON
	typ. -40 dBm		16FSK, 12.5 kHz, FEC ON
Spurious Rejection	typ. -39 dBm		4/8/16FSK, 12.5 and 25 kHz, FEC ON
Transmitter Power		0.01, 0.02, 0.05, 0.1, 0.2, 0.5, 1 W	
Communication Mode	Half-Duplex		
Frequency Change Time	typ. 20 ms		Time required for switching from one RF frequency to another
Adjacent Channel Power		<-60 dBc	TX-mode, 12.5 and 25 kHz. Acc. to EN 300 113 v2.2.1
Carrier power stability		< ±1.5 dB	During transmission.

¹ According to EN 300 113 V2.2.1 measurement setup.

	DATA MODULE	
Electrical Interface	CMOS-UART Inputs and outputs referred to IO Voltage processed by user (1.8-3.3V) RTS, CTS, RX, TX, +VCC, GND	
Interface Connector	1.27 mm pitch socket	Samtec 20-pin through hole, CLP-110-02-L-D-K-TR
Data speed of Serial interface	9600 – 115200 bps	
Data speed of Radio Air Interface	<u>4FSK FEC OFF / ON:</u> 19200 / 14400 bps (25 kHz) 9600 / 7200 bps (12.5 kHz) 4800 / 3600 bps (6.25 kHz) <u>8FSK FEC OFF / ON:</u> 28800 / 19200 bps (25 kHz) 14400 / 9600 bps (12.5 kHz) 7200 / 4800 (6.25 kHz) <u>16FSK FEC ON:</u> 28800 bps (25 kHz) 14400 bps (12.5 kHz) 7200 bps (6.25 kHz)	
Air Interface Encryption	AES128, AES256 (DRM option)	
Data Format	Asynchronous data	
Modulation	4-, 8-, 16FSK	

	GENERAL	
Operating voltage	+3.8...+5.5V	
Current consumption in Sleep1 mode	Typ. 510 mA	
Typical Power Consumption 320 ... 380 MHz	Sync search typ. 0.95 W	RX-mode
	Receiving data typ. 0.90 W	RX-mode
	SLEEP1: typ. 510 mW	RX-mode
	typ. 6.4 W @ 1 W RF out	TX-mode, Continuous, 50 Ω, CHBW 25.0 kHz
	typ. 4.9 W @ 0.5 W RF out	
	typ. 3.6 W @ 0.2 W RF out	
typ. 2.9 W @ 0.1 W RF out		
Inrush current, DC voltage turned ON	< typ. 17 A, duration < typ. 9 μs	
Temperature range	-20 °C ...+55 °C	Type Approval conditions
Temperature ranges	-30 °C ...+70 °C	Functional
	-40 °C ...+85 °C	Storage
Vibration	≤ 25 G, up to 2 kHz sinusoidal	MIL-STD-202G Test condition D MIL-STD-202G Test condition F MIL-STD-202H-213
ESD ¹	± 10 kV	Antenna connector. Acc. to EN61000-4-2; 150pF/330Ω
	± 8 kV	DTE connector. Acc. to EN61000-4-2; 150pF/330Ω
Antenna Connector	50 Ω, HIROSE U.FL compatible	I-PEX 20279-001 -E-01
Construction	PWB with sheet metal EMI shields	
Size L x W x T	57 x 36 x 6.9 mm	
Weight	20 g	

Test condition $V_{CC} = 4.2 \text{ V}$ and $T_A = 25 \text{ °C}$

- ¹ Measured under normal ambient conditions, $T_A = 25 \text{ °C}$. When the device is used in different environment, the results may change significantly. It is recommended to use external ESD protection in demanding conditions.

3 TIME PARAMETERS FOR STARTUP AND SHUTDOWN SEQUENCES

The following table shows the recommended times for startup and shutdown sequences.

Parameter	Recom. Time	Explanation
$t_{vccin-ena}$	>2 ms	VCC_IN must be high before ENA_MOD is high
$t_{enamod-io}$	>2 ms	ENA_MOD must be high before VCC_IO is high
$t_{enamod-cts}$	$100\text{ ms} < t_{enamod-cts} < 500\text{ ms}$	CTS ready settling time
$t_{vccio-cts}$	>2 ms	VCC_IO must be high before CTS is ready
$t_{vccio-gpio}$	>2 ms	VCC_IO must be high before GPIO PINS are active
$t_{gpio-cts}$	>0 ms	GPIOs must be active before CTS is ready
$t_{enamod-gpio}$	>80 ms	Input pins must be low after ENA MOD is low
$t_{gpio-vccio}$	>0 ms	GPIOs must be low before VCC_IO is low
$t_{vccio-vccin}$	>0 ms	VCC_IO must be low before VCC is low

3.1 Startup sequence

The following diagram will describe the startup sequence.

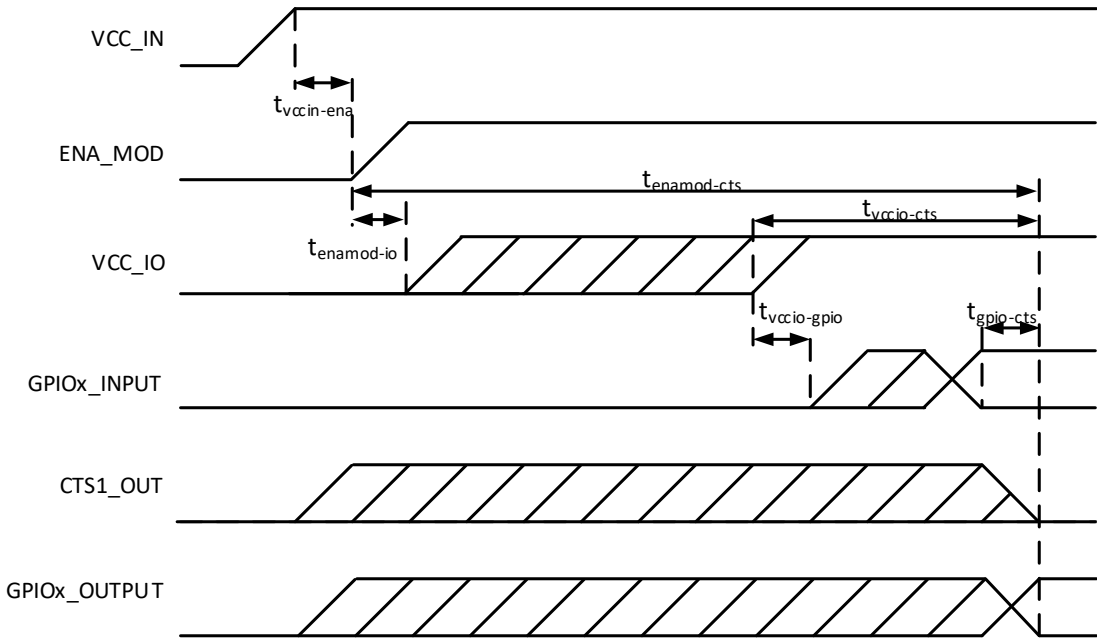

Figure 3.1 Startup sequence.

3.2 Shutdown and ENA sequences

The following diagrams will describe the shutdown and ENA sequences.

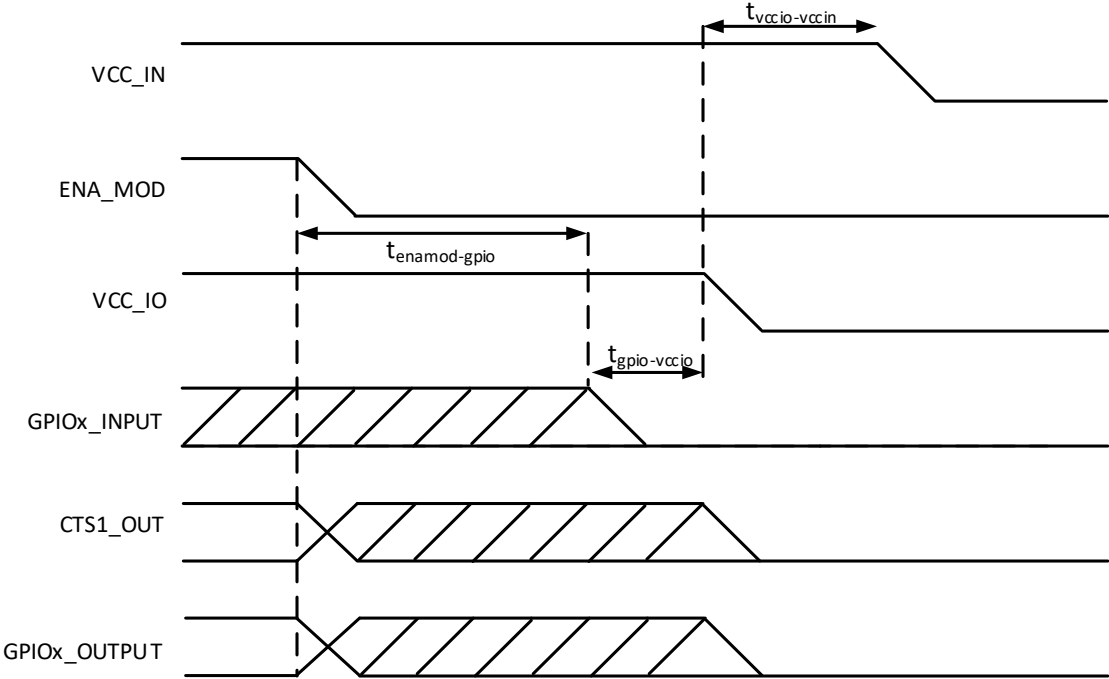

Figure 3.2 Shutdown sequence.

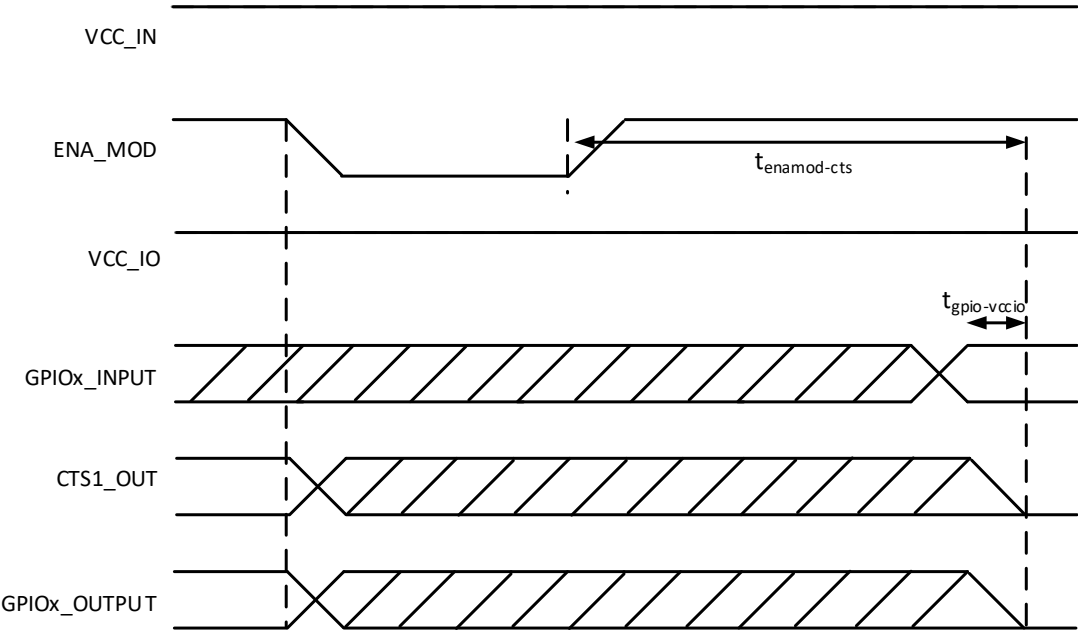

Figure 3.3 ENA sequence.

4 ELECTRICAL INTERCONNECTION

4.1 DTE connector

The DTE connector is a 20-pin pass-through connector. Connector is female two row 1.27 mm pitch. This connector allows the pin to enter the connector from the bottom side and protrude through the module PCB to the top side, allowing flexible mounting heights with various pin lengths. Alternative DTE connector assembly variants available. DTE connector assembled either BOTTOM or TOP side of the module.

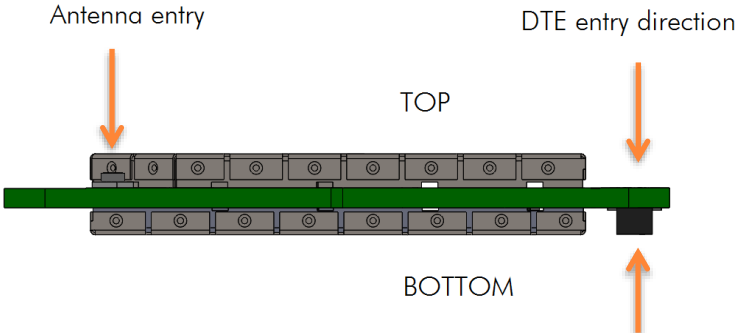

Figure 4.1 The side view of the module with connection directions.

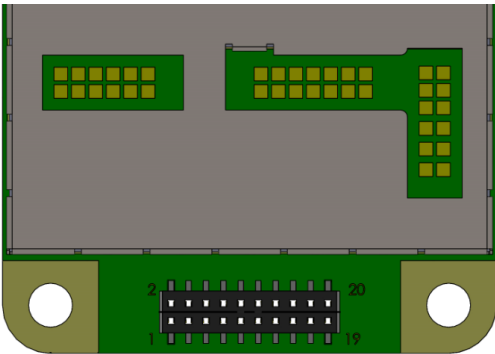

Figure 4.2 Pin numbering of 1.27 mm pitch DTE connector. View from bottom side of unit.

4.2 Pin order of the DTE connector

Direction **IN** is data from DTE (Data Terminal Equipment) to the radio transceiver module.
Direction **OUT** is data from the radio module to the DTE.

The equivalent I/O schematic figures are shown in the next chapter.

Pin no.	Equivalent I/O schematic	Signal name	Type	Direction	Pin state	Description
1,2	Figure 1	VCC_IN	POWER	IN	External Voltage	DC input
3,4	-	GND	GND	-	External Ground	Ground reference for power and signals
5	Figure 2	VCC_IO	POWER	IN	External Voltage	Device IO driver input
6	Figure 7	ENA_MOD	IO	IN	Internal Pull Down	Module ENA pin
7	Figure 3	RD1	CMOS	OUT	Output Driver	Receive data, active low.
8	Figure 3	CTS1	CMOS	OUT	Output Driver	Clear To Send, active low.
9	Figure 6	TD1	CMOS	IN	Internal Pull Up	Transmit Data, active low.
10	Figure 6	RTS1	CMOS	IN	Internal Pull Up	Ready to send, active low.
11	Figure 4	GPIO1	CMOS	OUT	Internal Pull Down	*)
12	Figure 4	GPIO2	CMOS	OUT	Internal Pull Down	*)
13	Figure 6	GPIO3	CMOS	IN	Internal Pull Up	*)
14	Figure 6	GPIO4	CMOS	IN	Internal Pull Up	*)
15	Figure 5	STAT	CMOS	OUT	Output Driver	Various sequences (section 4.7).
16	Figure 6	GPIO5	CMOS	IN	Internal Pull Up	*)
17	Figure 6	$\overline{\text{SERVICE}}$	CMOS	IN	Internal Pull Up	Input for service access, active low. See separate section of the manual (section 4.6).
18	Figure 4	GPIO6	CMOS	OUT	Internal Pull Down	*)
19	Figure 4	GPIO7	CMOS	OUT	Internal Pull Down	*)
20	Figure 4	GPIO8	CMOS	OUT	Internal Pull Down	Reserved for future use.

*) See separate document: TIL-0026_SATEL-Radio-Modules_GPIO-Interface.pdf

4.3 Equivalent I/O Schematics

The module input-output equivalent circuits are shown in the figure and the component values in the table below.

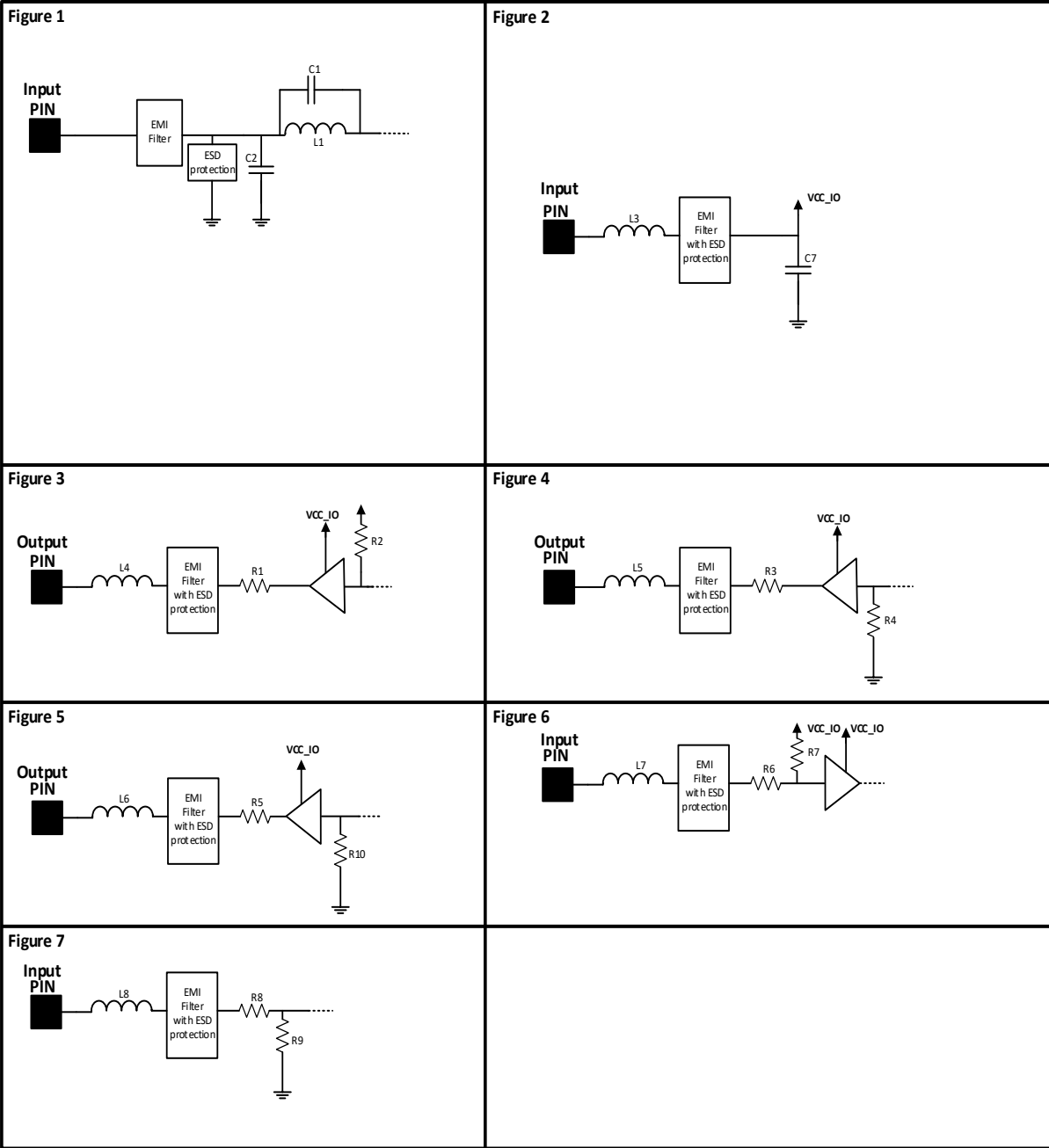

Figure 4.3 The module input-output equivalent circuits.

Component values of the equivalent schematics:

Component	Value	Note
C1	6.8 pF	
C2	1 uF	
L1	220 nH	
L3	1000 Ω +- 25%	Measured Impedance at 100 MHz
C7	100 nF	
L4	1000 Ω +- 25%	Measured Impedance at 100 MHz
R1	330 Ω	
R2	100 k Ω	
L5	1000 Ω +- 25%	Measured Impedance at 100 MHz
R3	330 Ω	
R4	100 k Ω	
L6	1000 Ω +- 25%	Measured Impedance at 100 MHz
R5	330 Ω	
L7	1000 Ω +- 25%	Measured Impedance at 100 MHz
R6	330 Ω	
R7	100 k Ω	
L8	1000 Ω +- 25%	Measured Impedance at 100 MHz
R8	1 k Ω	
R9	>1 M Ω	
R10	100 k Ω	

4.4 RF interface

The antenna interface is a 50 Ω coaxial connector. Matching networks are not included in the module and should be placed in the host application if the antenna is not 50 Ω . The HIROSE U.FL compatible connector is located on the TOP side of the board.

NOTE! The used connector has gold plated contacts - whereas a standard HIROSE U-FL has silver plated contacts.

If silver - gold joints are not allowed in your product, use gold plated cable-connector to mate to this device.

NOTE!

Setting the transmitter output power to such a level that exceeds the regulations set forth by local authorities is strictly forbidden. The setting and/or using of non-approved power levels may lead to prosecution. SATEL and its distributors are not responsible for any illegal use of its radio equipment and are not responsible in any way of any claims or penalties arising from the operation of its radio equipment in ways contradictory to local regulations and/or requirements and/or laws.

4.5 VCC_IO pin

VCC_IO pin determines the voltage level of UART signals and the voltage level of GPIO output signals. VCC_IO level also determines GPIO LOW/HIGH levels on each GPIO and UART input pins.

4.6 Service pin

The SERVICE pin is used to set the UART1 into a known state. Pulling this pin LOW will activate the service mode and set the UART1 into 38400, 8, N, 1. This is intended for service access of the module, to have a known serial port setting in order to provide easy access to module settings.

The pin does not affect any permanent settings, nor does it change the mode of the module. It is recommended to pull high or pull up by resistor to VCC_IO to return serial port 1 into the configured state. When service pin is LOW the SL Commands are temporary forced to be ON

4.7 Stat pin

The STAT-pin indicates the status of the device. It can be used to drive or sink an LED current using a proper series resistor. STAT-pin drive or sink capability is +/-10mA at 3.3 V. It is recommended to use VCC_IO for LED current.

Notice that if STAT-pin is used to sink LED current, LED behavior is opposite to driving scheme. The behavior of the STAT pin is described below.

Blink cycle	Mode
“1” - statically	Module is operational “searching for a new frame”
“0” for the endurance of the received frame.	“0” when module is receiving data from air interface. In practical cases will toggle at the frequency of the data packets on the air interface.
“0” statically	Module is in sleep1 mode
The pin is toggled in transmission interval	Module is sending data Over the Air
Pin is toggled in 1 s interval	Module has the connection to configuration SW tool.
Pin is toggled in 500 ms interval	SL command mode set to OFF and SL commands enabled using “+ + +” sequence, section 7.2.
Pin is toggled in 250 ms interval	Module has detected a fault; fault codes can be read via SW tools.

4.8 VCC pins

VCC pins are to feed operating voltage to the module. The limit for this voltage is mentioned in chapter 2.2 DC electrical specifications. Users must take into consideration surge current and current consumption issues before using these pins. Also, the user must be aware of any voltage drop on the feeding path.

4.9 UART pins

Pins 7, 8, 9, 10 are used for UART serial transmission between the module and the terminal. The UART signal level corresponds to the level in VCC_IO pin. VCC_IO pin must be fed with a correct voltage level to match the terminal device.

4.10 GPIO pins

See separate document: TIL-0026_SATEL-Radio-Modules_GPIO-Interface.pdf

Unused pins should be left unconnected.

5 MECHANICAL CONSIDERATIONS

5.1 Fixing device to host

The radio module can be mounted on to the host application by using spacers and screws. It is highly recommended to use conducting metal spacers and screws to create proper electrical conductivity between the module and the host application. Recommended materials for spacers include brass or aluminum and steel screws. Users must take care that there is no excessive mechanical stress created to the DTE connector while inserting and attaching the module. Recommended maximum screw size is M3 for the PCB, minimum spacer height between the module and the host application is 3 mm. Please contact SATEL or local SATEL distributor for heat sink piece models availability.

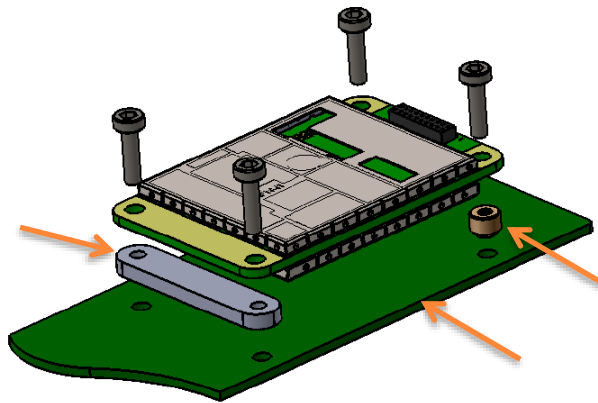

Figure 5.1 Example of module attachment to application PCB.

5.2 Heat transfer

Since the module creates heat while operating, it must take into consideration to maximize the heat transfer from the module to an external heat sink. Proper heat sinking methods could be copper plated PCB, metal housing or a heat sink piece. The most recommended solution is to use a metal conductor to transfer heat from the module to an external heat sink which dimensions and location is adequate for proper performance. To source the heat from the module is the plain area next to the antenna connector shown in figure 5.2. Heat can be conducted from either side. To further improve the heat conductivity and reduce the heat transfer barriers, proper heat conducting paste or heat conducting tape should be used. For any additional information please contact SATEL or the local SATEL distributor.

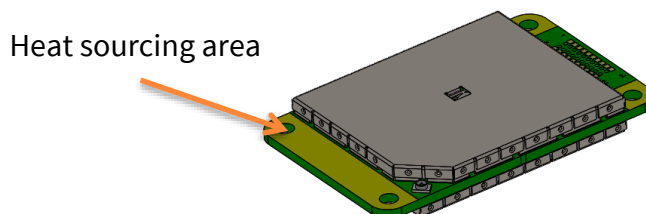

Figure 5.2 Heat sourcing area, both sides.

6 OPERATING MODES

The radio transceiver module has the following modes of operation:

MODE	FUNCTION	DESCRIPTION
Ready to receive from RF	Search for sync	Module is searching for the start of a radio transmission from the RF signal.
	Receive data	The module has found a valid radio transmission and is receiving data.
TX	Transmit	The module transmits
Safe mode		Mode is entered when a fault has been detected and the device has been Rebooted. In safe mode fault codes can be read from the module (section 6.1).
Sleep mode	Sleep1	Will turn the module into a state where it will hold parts of the radio on, wakeup time see section 2.3
Power Save mode	Power save	Automatic sleep/wake-up procedure where module sleeping time is dynamically adjusted to received data packets. Decreases the power consumption of complete receiving cycle approx. 30%.

6.1 Japan regional specific features

Carrier Sense feature

Carrier sense feature is intended to use with certain region codes to achieve country specific RF specifications.

This feature works only with region codes where it is required, e.g., with Japan region code, to prevent device to transmit if it senses another signal in current channel to be stronger than given threshold before going to transmit state. When transmit is prevent, all buffered data is discarded.

Carrier sense threshold is adjustable (see SL commands) with range -60 ... -117 dBm. Value -118 dBm will turn this feature OFF.

Detailed SL commands required for carrier sense can be found in SL commands list. Please contact SATEL Oy for the latest SL commands list.

Transmit time limitation

This feature is used to limit transmit time in certain region codes to achieve country specific transmitter time limitations, defined in RF specifications.

E.g., Japan region time limit will be five (5) minutes. If time limit was reached, transmitter is prevented to transmit for one (1) minute. Receiver will work normally within this time.

Transmitter Call ID

This feature works only with region codes where it is required, e.g., with Japan region code. Transmitter Call ID means that the modem sends a transmission ID with each transmission. The transmit ID is a 9-character identifier that is unique for each device.

Transmit ID Call sign is configured using a SATEL SL-command

- a) Set the transmitter Call ID with the command SL%CID=<max. 9 digit>
- b) Transmitter Call ID query with the command SL%CID?

Detailed SL commands description for transmitter Call Id can be found in SL commands list. Please contact SATEL Oy for the latest SL commands list.

6.2 Safe mode

When a fault has been detected by the Firmware, the module is set to Safe mode. In this mode the module toggles the STAT pin in 250 ms interval indicating an Error and reboots the device after 5 s. Transmitting/Receiving is prohibited during malfunction. When connecting to the device with SATEL Configuration Manager the Error code is shown in pop up box. If the device does not recover after multiple reboots, please contact SATEL Oy.

SATEL Configuration Manager can be downloaded from website <https://www.satel.com/support-and-services/downloads/>. Version 1.17.0 or newer is compatible with SATEL-TR300 radio transceiver module.

6.3 Power up / power down scenarios

The transceiver module can be set in four (4) states, “ON”, “OFF”, “Sleep1” and “Power Save”. When power is applied to the module, the module switches to ON state when voltage in ENA_MOD is set to HIGH.

The module can be shut down by driving ENA_MOD line to LOW state. In the “OFF” state current consumption is only that of leakage current from an LDO, section 2.3. In this state all non-essential parts of the module are powered down and all settings/state information that are not stored in nonvolatile memory are reset.

6.4 Sleep Mode

When in sleep mode, the radio part of the module is switched OFF while the serial interface communication related parts remain powered ON. The module will be automatically woken up after the CPU senses a state change in the TD1 pin. *Example:* The module is in Sleep1- mode. The module is woken up by sending a character or characters into the TD1 pin after which the module responds “OK”. After “OK” the module is ready for normal communication.

To turn the module ON from Sleep1 mode:

- 1) Issue a state change to TD1 (toggle pin (minimum pulse duration time 10 μ s) or issue a byte on the UART (for example 0x00))
- 2) Wait for “OK” -response from the module. The wake-up time is approx. 30 ms.
- 3) Start communicating normally

Module will remain powered ON until a new sleep command is issued.

6.5 Power Save Mode

The Power save mode performs an automatic, self-adjusting receiver wake-up/sleep cycle. It is designed for applications which are based on one-way communication with relatively constant TX interval and, in which the data packet separation is > 200 ms.

When enabled, the unit makes the *transmission interval study* based on four (4) successfully received data packets. The shortest time between transmitted packets is measured (t_{min}). Measured value is updated after each successfully received data packet, so that possible changes in the message length become noted.

Ensuring that the complete messages will be received even if there occurs little variation in transmission interval, some safety margin (t_{marg}) is left into Ready to receive from RF mode time.

Safety margin is calculated by dividing the shortest time between transmitted packets (t_{min} , in ms) with 8 and by adding 60 ms to this result:

$$t_{marg} = \frac{t_{min}}{8} + 60 \text{ ms}$$

The length of the whole sleeping period (t_{sleep}) is calculated by decreasing the shortest time between transmitted packets (t_{min}) with safety margin (t_{marg}) and transmission time of the original message (t_{TX}):

$$t_{sleep} = t_{min} - t_{marg} - t_{TX}$$

Transmission interval study is started over always after 100 successful sleep/wake-up cycles and, if the expected receiving slot ($t_{RX\ slot}$) with enhanced overlap margin ($t_{overlap}$) has been missed. In the latter case the package is considered to be lost.

$$t_{overlap} = t_{marg} + 100\ ms$$

$$t_{RX\ slot,\ min} = t_{min} - t_{marg}$$

$$t_{RX\ slot,\ max} = t_{min} + t_{overlap}$$

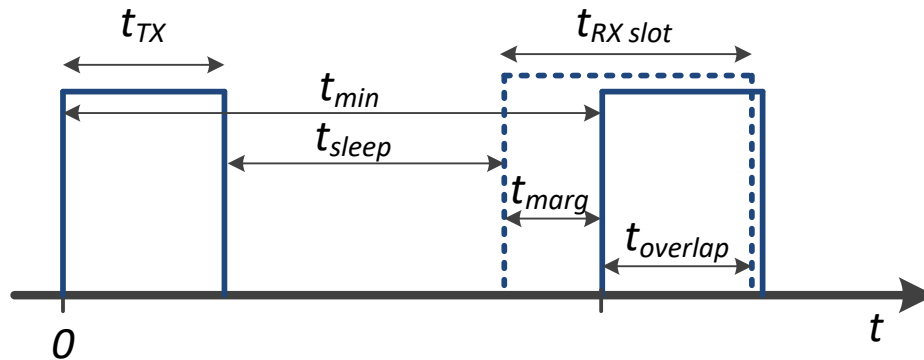

Figure 6.1 Power save mode timing factors.

E.g. In system with TX interval of 1 s, and with 300 ms (approx. 300B @ 9600 bps) transmission time:

$$t_{min} = 1000\ ms$$

$$t_{TX} = 300\ ms$$

$$t_{marg} = 125\ ms + 60\ ms = 185\ ms$$

$$t_{sleep} = 1000\ ms - (125\ ms + 60\ ms) - 300\ ms = 515\ ms$$

$$t_{RX\ slot,\ min} = 1000\ ms - 185\ ms = 815\ ms$$

$$t_{RX\ slot,\ max} = 1000\ ms + 285\ ms = 1285\ ms$$

6.6 Restart

After startup the module can be restarted by issuing an SL command, upon which the module will shut down all circuitry, and Reboot the CPU (see SL command list).

7 CONFIGURATION

The configuration of settings can be changed easily - the next chapters describe the details:

SATEL SW tools

Easy-to-use SATEL software tools suit most cases. Please see additional information in next chapters.

SL commands

A terminal device can command or configure the radio modem by using special commands. SL commands are applied especially in cases where radio modems are to be integrated seamlessly inside a system behind the integrator's own user interface.

7.1 SATEL NETCO DEVICE software

SATEL NETCO DEVICE is a software for configuring and reprogramming a SATEL device. The configuration parameters can be read and written from/to the locally connected, powered device. The device configuration can be also created/saved/explored from/to a file without device connection.

The most common use case for which the SATEL NETCO DEVICE is optimized for is editing existing parameters in a SATEL radio product using local connection, such as serial interface.

Please see additional information from SATEL WEB pages at:

<https://www.satel.com/products/software/>

The software is available from SATEL WEB pages at: <https://www.satel.com/support-and-services/downloads/>

7.2 SATEL Configuration Manager software

SATEL Configuration Manager is a software for configuring and reprogramming a SATEL device. The parameters can be read and written from/to the connected, powered device. The program file can be saved into a separate file to be used to other devices.

The most common use case for which the SATEL Configuration Manager is optimized for is editing existing parameters in a SATEL radio product using locally connected product over a serial interface. Minimum requirements: COM port with baud rate min. 9600 bps (alternatively with industrial level USB-RS-232 converter).

Please see additional information from SATEL WEB pages at:

<https://www.satel.com/products/software/>

The software is available from SATEL WEB pages at: <https://www.satel.com/support-and-services/downloads/>

7.3 Changing parameters using SL commands

The controlling terminal device can change the configuration settings of the module. This is accomplished with the help of SL commands. SL commands can be used to change e.g. the frequency or addresses. It is also possible to ask the radio transceiver module to show current settings which are in use.

7.3.1 SL Commands

The controlling terminal device can change the configuration settings of a radio. This is accomplished with the help of SL commands, which can be used during data transfer. SL commands can be used to change e.g. the frequency or addresses. It is also possible to interrogate a radio modem to gain information concerning current settings that are in use. SL command -setting must be enabled before they can be used.

An SL command is a continuous string of characters, which is separated from other data by pauses which are equal or greater than time defined by Pause length parameter (default=3 characters) in the set-up. No extra characters are allowed at the end of an SL command. Serial interface settings are the same as in data transfer. SL command is properly recognised also in the case when the command string is terminated by <CR> (=ASCII character no. 13, Carriage Return, 0x0d) or <CR><LF> (<LF> = ASCII char. no. 10, Line Feed, 0x0a). Pause according to set Pause Length -parameter is required also in this case. If multiple SL commands are sent to the module, the next command can be given after receiving the response ("Ok" or "Error") of the proceeding command. In addition, it is recommended to implement a timeout to the terminal software for recovering the case when no response is received from the radio module.

The transceiver module will acknowledge all commands by returning an "**OK**" (command carried out or accepted) or the requested value, or an "**ERROR**" (command not carried out or interpreted as erroneous) message. SL command response time depends on the used command. Typical response time is ~100ms and upwards. Recommended safe timeout for SL command response is 500ms.

it is possible to use SL commands in Port 2 (TD2 signal in GPIO3 (Pin13) and RD2 signal in GPIO1 (Pin11)) when Port2 Function has been configured as Diagnostics. SL commands can be used even in parallel with Port1 – in that case the response appears in the same port where the SL command came from.

Port2 is configured via SL commands or SW tools (SATEL NETCO DEVICE or SATEL Configuration Manager) by selecting the Port2 Function:

- OFF (=Port 2 not in use)
- Diagnostics (=SL commands ON in this case)

CR/LF characters are added to end the response messages (unless they are already present) to make parsing easier. Settings can be toggled, SL Commands ON/OFF, CR/LF ON/OFF.

To get information of the latest and/or special SL commands please contact SATEL or local SATEL distributor: <https://www.satel.com/where-to-buy/>.

7.3.2 SL Command Mode

When the SL commands are enabled, there are possibilities that the user data may start with the characters “SL” which is handled as the SL command. This has caused the firmware to go to the continuous SL command search mode and any data has not been sent or even an “**ERROR**” acknowledgment has been received. To avoid this kind of behavior the user can disable the SL commands.

The SL commands can be disabled or enabled by using SL commands or toggling the “*SL Command mode*” parameter via SATEL SW tools, SATEL NETCO DEVICE or SATEL Configuration Manager (maintenance access level required).

By default, the *SL Command mode* is set to **ON**. If the *SL Command mode* is set to **OFF**, then the SL commands can be enabled or disabled by using the below described procedure. Regardless of the original SL command –setting state, changing the setting state with this procedure will affect the reception process of the radio module.

Radio can be set to *Command Mode* separately with “+++” command, regardless of the set SL command mode (ON/OFF). *Command mode* enables forcibly the SL command mode and disables the radio interface functions (Tx/Rx). By exiting from the Command Mode, user defined SL command parameter mode is restored, as well as radio interface functions.

To enable the *Command mode*:

- Send three “+” characters via serial port so that there is at least three bytes delay (according to Pause Length -setting) between each character. The response is “**OK**”, when successfully set.
`<+><at least three bytes pause*><+><at least three bytes pause*><+>`

To disable the *Command mode*:

- Send three “-” characters via serial port so that there is at least three bytes delay (according to Pause Length -setting) between each character. The response is “**OK**”, when successfully set.
`<-><at least three bytes pause*><-><at least three bytes pause*><->`

**Pause Length -setting*

Note!

The “+ + +” and “- - -” procedures are not recommended to be used when radio is transmitting or receiving data (i.e., the application data occupies the TD or RD lines of the radio).

8 SERIAL INTERFACE

The radio modem is referred to as DCE (Data Communication Equipment) whereas the device connected to it, typically a PLC or a PC, is referred to as DTE (Data Terminal Equipment).

To transfer data, the physical interface between DCE and DTE must be compatible and properly configured. This chapter describes shortly the basics of the physical interface options, the related settings and the operation of the serial interface.

Before connecting DTE (Data Terminal Equipment) to the radio modem, make sure that the configuration matches the physical interface (electrical characteristics, timing, direction and interpretation of signals).

8.1 Pause length

The modem recognises a pause on the serial line (a pause is defined as a time with no status changes on the UART interface TD-line). The pause detection is used as criteria for:

End of radio transmission - When the transmit buffer is empty and a pause is detected, the modem stops the transmission and will then change the radio to the receive mode.

SL command recognition - For a SL command to be valid, a pause must be detected before the actual command character string.

User address recognition - For the start character to be detected, a pause must precede it in transmission.

Traditionally, in asynchronous data communication, pauses have been used to separate serial messages from each other. However, the use of non-real-time operating systems (frequently used on PC-type hardware) often adds random pauses, which may result in the user data splitting into two or more separate radio transmissions. This may cause problems especially in the systems including repeater stations.

To match the operation of the radio modem to the user data, the Pause length parameter can be adjusted on the programming menu. It may have any value between 3 and 255 characters. The default value is 3 characters.

Notes:

The absolute time of Pause length is depending on the serial port settings. For example, 1 character is ~1.04 ms at 9600 bps / 8N1 (10 bits).

The maximum absolute time is always 170 ms independent from the value of the Pause length given in the set-up.

An increase in the Pause length increases the round-trip delay of the radio link correspondingly; this is because the radio channel is occupied for the time of the Pause length after each transmission (the time it takes to detect a pause). If this is not acceptable, the TX delay setting may also be useful in special cases.

8.2 Data buffering

Whenever the radio modem is in *Data Transfer Mode* it monitors both the radio channel and the serial interface. When the terminal device starts data transmission the radio modem switches to transmission mode. At the beginning of each transmission a synchronisation signal is transmitted, and this signal is detected by another radio modem, which then switches into receive mode. During the transmission of the synchronisation signal the radio modem buffers data into its memory. Transmission ends when a pause is detected in the data sent by the terminal device, and after all buffered data has been transmitted. When the serial interface speed is the same or slower than the speed of the radio interface, the internal transmit buffer memory cannot overflow. However, when the serial interface speed exceeds the speed of the radio interface, data will eventually fill transmit buffer memory. In this instance, it will take a moment after the terminal device has stopped transmission of data for the radio modem to empty the buffer and before the transmitter switches off. The maximum size of transmit buffer memory is one kilobyte (1 kB). If the terminal device does not follow the status of the CTS-line and transmits too much data to the radio modem, the buffer will be emptied, and the transmission is restarted.

In the receive mode, the buffer works principally in the above-described way thus evening out differences in data transfer speeds. If the terminal device transmits data to a radio modem in receive mode, the data will go into transmit buffer memory. Transmission will start immediately when the radio channel is available.

9 RADIO PARAMETERS

This product offers the radio settings for user to select:

- Channel spacing: 25, 20, 12.5 or 6.25 kHz
- Frequency can be any 6250 Hz divisible frequency with 6.25, 12.5 and 25 kHz channel spacing options
- Frequency can be any 10000 Hz divisible frequency with 20 kHz channel spacing option

9.1 Transmitter

The output power of the transmitter is adjustable (0.01, 0.02, 0.05, 0.1, 0.2, 0.5, 1 W). The greatest allowable power depends on limits set by local authorities, which should not be exceeded under any circumstances. The output power of the transmitter should be set to the smallest possible level such that it still ensures error free connection under variable conditions. Excessively high output power levels used in short link spans can cause interferences and affect the overall operation of the system.

The antenna (or a 50 Ohm attenuator) should be always connected to the antenna connector while the transmitter is being used to guarantee the maximum lifetime of the transmitter.

9.2 Receiver

The sensitivity of the receiver depends on the channel spacing of the radio modem, selected modulation level and on the mode of the FEC (error correction).

The radio modem measures the received signal strength (RSSI) of the receiver constantly. The Signal Threshold setting determines the received signal level above which the search for the radio messages is active. It is recommended that values given in the table above are used as a basis. If the threshold is set too low, it is possible that the receiver is trying to synchronise itself with noise. In such a case the actual data transmission might remain unnoticed. If the threshold is set too high, the weak data transmissions will be rejected although they could be otherwise receivable. Signal threshold should only be changed for a reason - for example in the following cases:

Continuous interference is present, and the desired signal is strong. In this case the signal threshold can be increased to prevent the modem from synchronising to the interfering signal(s) and /or possible noise.

Maximum sensitivity should be achieved, and the desired signal is very weak. In this case the sensitivity could increase by decreasing Signal threshold. This type of situation is usually a sign of a poorly constructed radio network / contact. Bit errors and momentary loss of signals can be expected in this kind of a situation. Some data might be successfully transferred.

The RSSI can be requested also locally by using a special SL command (SL@R?). The RSSI value is available 7s after the receiving the message.

Signal Threshold value range: -80 ... -118 dBm

Default value: -118 dBm

Note that the feature is OFF in case the value is -118 dBm.

9.3 Encryption

Data security is often a concern when using radio communication. In SATEL radio products, strong AES128/256-bit encryption (CTR-mode) on the air interface ensures privacy in the radio network. The principle of encryption in the radio path is to collect a certain amount of data to a shift register and manipulate it according to a certain rule. Every data packet is encrypted individually. The process of encryption adds 5 to 10 ms (depending on encryption mode) to each sent data packet (<5 characters) and must be avoided in the cases where low latency is the most important requirement.

AES is open-source software from public domain. Author: Brian Gladman (U.K). The CTR-mode is SATEL's in-house implementation.

The product models that support the encryption for the RF interface can be viewed in SATEL WEB sites at www.satel.com/products/. The radio models that do not support the encryption feature are compatible with the radio models with the encryption when the feature is disabled. The factory default value for the encryption feature is OFF state.

It is not possible to update/change the models NOT supporting the encryption to support this feature in the field. This task can be executed in SATEL factory premises and will be charged according to the service price list. The factory default value for the encryption feature is OFF state. The setting state with the static, distributed encryption keys must be set equally to the radios in the same radio network.

Please contact SATEL for more detailed information regarding the radio network compatibility settings in radio network between different models (channel width, radio frequency etc.).

The encryption password key is generated by using Main and Aux –keys + in the beginning of the data packet transferred changing 32/64-bit string. It is mandatory to insert both information keys with the mentioned length keys. Options for generating the encryption keys are:

- Manually via terminal connection:
 - o SL commands
- Automatically with password via SATEL NETCO DEVICE or SATEL Configuration Manager software (generates automatically the Main and Aux keys)

It is recommended to set up a radio network with encryption enabled by using only one selected configuration way. The password or the keys should be kept in a safe place as the keys can't be read from the device after configuration. The equivalency of the encryption keys between radio modems can be verified from the Key Hash –information field. Last 4 marks indicates the equivalency [0-9, A-F]. In case the password is forgotten, a new password will need to be set for all the radios of the network.

NOTE! The encryption is designed for SATELLINE-3AS, SATEL-8FSK-1, SATEL-8FSK-2 and SATEL-16FSK-1 –radio compatibility modes.

9.4 Radio state

This setting allows users to disable/enable the transmitter. Unless overridden by the factory configuration, users can select state of the radio by using SATEL NETCO DEVICE or SATEL Configuration Manager software and selecting the value Enabled Radio States:

- Tx/Rx (both transmitter and receiver are enabled)
- Rx Only (transmitter out of use, receiver enabled)

In case the factory configuration defines the modem as Rx-only device, the value can't be changed by the users.

NOTE! Rx Only device replies "0mW" to SL@P? (Get transmitter power) command.

9.5 Priority RX/TX

Priority setting selects the priority between reception and transmission. The setting can be changed either via SL commands or SW tools (SATEL NETCO DEVICE or SATEL Configuration Manager). By default, transmission has higher priority than reception i.e., the default value is Priority TX.

Priority TX means that the device attached to a radio modem decides the timing of the transmission. The transmitter is immediately switched on when the terminal device starts to output data. Should reception be in progress, the radio modem will stop it and change to a transmit state. There is no need to use any handshaking for the control of timing.

Priority RX means, that a radio tries to receive all data currently in the air. If a terminal device outputs data to be transmitted (or an SL command) it will be buffered. The radio modem will wait until the reception has stopped before transmitting the buffered data. This will result in timing slacks to the system but decreases the number of collisions on the air; this is particularly useful in systems based on multiple random accesses.

9.6 Forward Error Correction (FEC)

FEC improves the reliability of data transfer over the radio by adding additional correction information to the radio messages. Based on that information, the receiving radio modem will be able to correct erroneous bits provided the ratio of erroneous and correct bits is reasonable. However, the use of FEC decreases the data throughput because the amount of transmitted data increases about 30 %. FEC should be used on long distance links and/or if the radio channel is "noisy" in other words suffering from interfering signals.

NOTE! All radio modems, which are to communicate with each other, must have the same setting for FEC (ON or OFF). If the transmitting radio modem and the receiving radio modem has different settings, data will not be received.

9.7 Error checking

When the error checking is switched on, the radio will add a checksum to the transmitted data. When the data is received, the checksum is verified before data is forwarded to the serial port. Options for error checking can be accessed either via SL commands or SW tools (SATEL NETCO DEVICE or SATEL Configuration Manager). Error Check modes:

OFF (default setting). Received data is not verified at all. In practice, this is the fastest way to operate, because the data is given out from serial port immediately after it has been received. This is recommended method if the application protocol already includes error checking functions.

CRC8 Partial verifies the data in small blocks, and they are delivered to DTE as sub messages after validating. Once an error is detected, the rest of the message is ignored. In practice, if the error appears in the middle of the message, the first part is forwarded to DTE and the data in erroneous sub-message and after that will be lost.

CRC-16 Full and CRC-8 Full check adds checksum characters accordingly at the end of the user data message. At the reception end the receiver receives first the whole package and if the checksum matches the data message is forwarded to the serial port.

! CRC-8 Partial and CRC-8 Full check activate an internal control on the radio link. These checksum types can't be viewed in the serial line data flow. CRC-16 Full check adds the checksum to data. It is possible include the checksum into the received data in the serial line by setting the CRC-16 Full check to OFF state at the receiving radio(s).

In typical use case, if checksum is preferred in the system, it is recommended to use the CRC-16 Full check -mode and set the parameter equally to the radios in the same radio network. Additional data transfer delay will be added approximately according to the data packet size to the total transfer delay.

NOTE! This feature is designed for SATELLINE-3AS, SATEL-8FSK-1, SATEL-8FSK-2 and SATEL-16FSK-1 -radio compatibility modes.

9.8 TX Delay

The transceiver can be configured to delay the beginning of a radio transmission by 1...65000 ms. The function can be used to prevent packet contention in a system, where all substations would otherwise answer a poll of a base-station simultaneously. During this delay data sent to the radio modem is buffered. Even when the priority setting is "RX", the radio modem is prevented to change over to the receiving mode during the period of the TX delay. If TX delay is not needed, its value should be set to 0 ms.

9.9 Add RSSI to data

RSSI info "\02RSSI:-nnn dBm\03\0D\0A" will be concatenated to the end of serial port messages, nnn is three digit decimal number.

9.10 Separate TX/RX frequencies

Modem can transmit (TX-frequency) and receive (RX-frequency) on separate frequencies. The switch between the frequencies introduces an extra 40 ms delay in the data transfer that must be taken account when designing the system.

9.11 User data whitening

In some cases, if the user data includes a large number of constant characters, additional bit errors may appear. The use of error correction (FEC) is recommended in such cases. If that is not possible, the Data whitening feature can be used to improve the reliability of data transfer. The parameter can be adjusted via SL commands, "SL%W=n". Value of n: 0 = OFF, 1 = ON. "SL%W?" = Get data whitening.

NOTE!

All radio modems, which are to communicate with each other, must have the same setting for Data whitening (ON or OFF). If the transmitting radio modem and the receiving radio modem has different settings, data will not be received correctly.

NOTE! This feature is designed for SATELLINE-3AS, SATEL-8FSK-1, SATEL-8FSK-2 and SATEL-16FSK-1 –radio compatibility modes.

9.12 Channel list

A list of predefined radio channels can be stored in the memory in order to change the radio settings simply by switching between the channels. Each channel carries the following info:

- Channel number (any number -32767...32767)
- Transmitter/Receiver frequency
- Channel width (12.5, 20 or 25 kHz)
- Transmitter power level (optional)

Additionally, the default channel that the radio modem uses after a reset is defined.

When TX frequency of the active channel is set to 0, the radio modem operates as receive-only device (in case the value of Rx frequency is valid).

Channel lists can be created and utilized by using either SATEL NETCO DEVICE or SATEL Configuration Manager software tools or SL commands. Software tools provide a channel list editor (snapshots below) for creating and saving a channel list in the radio modem, or in a file for later usage.

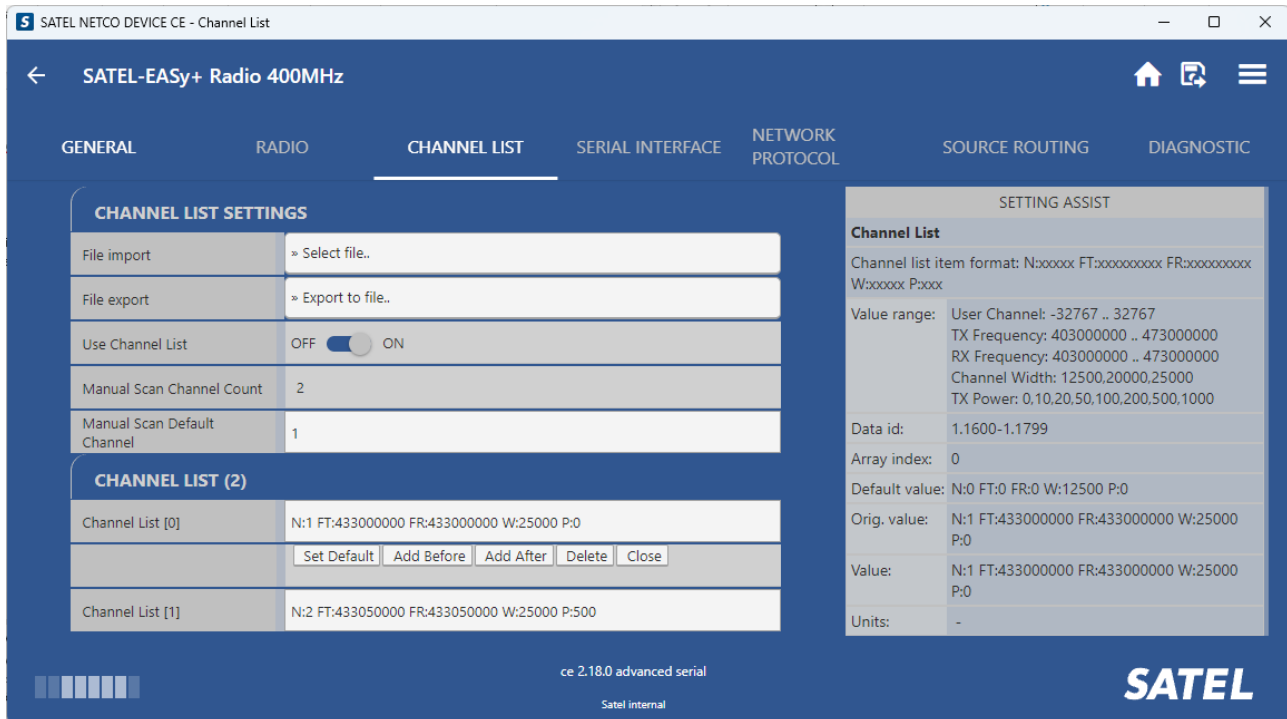

SATEL NETCO DEVICE.

Channel Selector

Default Channel Set

Clear Load Save Add Edit Up Down Set default Delete Close

Index	User Channel	TX Frequency	RX Frequency	Channel Width	Tx Power
0	0	430000000	430000000	12500	1000
1	1	431000000	431000000	12500	1000
2	2	432000000	432000000	12500	1000

SATEL Configuration Manager.

Entering the Channel List -feature parameters require elevated access level to software tools.

SL commands provide an interface for a host device to command the radio modem directly. An example of the procedure for creating or replacing a channel list:

1. Clear existing channel list (SL\$C=0)
2. Set channel info for each of the channels to be created starting from index 0 (SL\$L=)
3. Set number of channels in channel list (SL\$C=)
4. Set the default channel (SL\$D=)
5. Verify the new configuration:
 - Get number of channels in channel list (SL\$C?)
 - Get channel info for each of the channels (SL\$L?)
 - Get the default channel (SL\$D?)
7. Enable Channel list (SL\$M=1) in order to activate the Channel list
8. Save the settings (SL>**>)

9.13 Repeater –mode

Repeaters and addressing may be used to extend the coverage area of a radio modem network, and to direct messages to selected radio modems in the network. In large systems, with several repeaters and formed repeater chains, it is often practical to use routing instead of plain addresses.

In circumstances where it is necessary to extend the coverage area of a radio modem network, modem can be used as repeater stations.

The maximum size of a repeated data packet is 1 kB (kilobyte). The Repeater Function is switched on in the radio settings. In the repeater mode the radio modem will function as a totally independent unit. Other devices are not necessary.

A radio modem acting as a repeater can also be used to receive and transmit data. In repeater mode the radio modem will transmit the received data to the serial interface in a normal fashion. The difference being that the received data will be buffered into the buffer memory. After reception the radio modem will re-transmit the buffered data using the same radio channel as in reception. Data received through the serial interface a radio modem in repeater mode will transmit normally.

The same network may include several repeaters, which operate under the same base station. Repeaters may also be chained; in which case a message is transmitted through several repeaters. In systems with more than one serially or parallelly chained repeater, addressing or routing protocol must be used to prevent a message ending up in a loop formed by repeaters, and to ensure that the message finally reaches only the intended radio modem.

Please contact SATEL for more information of Repeater- and Addressing –features.

10 TEST MODES

The radio modem can be switched to a Test Mode in which it will send test messages to the radio channel. Test messages can be utilized for example when directing antennas during system installation. The transmitting radio modem needs only a power supply and an antenna in the test mode but no external terminal device. If the test mode has been set ON, the radio modem starts to transmit test messages immediately after a reset or a power-up. Test messages are treated as normal data at the receiver side.

10.1 Short Block Test

In this test mode the radio modem sends a short test message that is preceded by a consecutive number and terminated by the Carriage Return and Line Feed characters. The test messages are repeated continuously at 1 second intervals. The short block test is suitable for running radio link tests. Reception of data can be monitored using a suitable terminal program.

Example of short data blocks:

```
00 This is a testline of SATELLINE-3AS radio modem
01 This is a testline of SATELLINE-3AS radio modem
```

10.2 Long Block Test

In this test mode the radio modem transmits a test message continuously for 50 s. After 10 s break the test transmission is started again. The transmission sequence is repeated continuously. The long block test can be used to measure the transmitter output power, standing wave ratio (SWR) of the antenna system or RSSI (Received Signal Strength Indicator) level at the receiver stations. RSSI can be monitored easily on the LCD display of the receiving modem or by using SL command "SL@R?".

Example of a long data blocks:

```
99 This is a long testline of SATELLINE-3AS radio modem
00 This is a long testline of SATELLINE-3AS radio modem
```

Note1. Remember to set the test mode OFF before starting the normal data transfer.
Note2. The Test -modes are designed to be used in "SATELLINE-3AS" compatibility mode.

11 DEFAULT DELIVERY VALUES

DEFAULT VALUES OF THE USER ADJUSTABLE SETTINGS		
Setting	Default value	Range
Radio frequency		
Operating TX and RX frequency	350.000 MHz	320 - 380 MHz
Channel Spacing (equals channel width)	12.5 kHz	6.25, 12.5, 20, 25 kHz
Transmitter Output Power	1 W	0.01, 0.02, 0.05, 0.1, 0.2, 0.5 and 1 W
Radio settings		
Radio Compatibility	SATELLINE-3AS	SATELLINE-3AS SATEL-8FSK-1 (FEC OFF) SATEL-8FSK-2 (FEC ON) SATEL-16FSK-1 (FEC ON) Alinco
Addressing		
RX Address	OFF	ON/OFF
TX Address	OFF	ON/OFF
Serial port		
Data speed	115200 bps	9600 -115200 bps
Data bits	8	8
Parity bits	None	None, Even, Odd
Stop bits	1	1
Handshaking		Handshaking lines apply to the DATA-port
CTS	TX Buffer State	Clear to send, TX Buffer State
RTS	Ignored	Ignored, Flow Control
Additional setup		
Error Correction, FEC	OFF	ON/OFF
Error check	OFF	OFF, CRC8Partial, CRC8Full, CRC16Full
SL Command Mode	ON	ON/OFF
Repeater Mode	OFF	ON/OFF
TX Delay	0	0 65535 ms
Over-the-Air-Encryption	OFF	ON/OFF
Use Channel List	OFF	ON/OFF
Power Save Mode	OFF	ON/OFF
Add RSSI to Data	OFF	ON/OFF
Radio state	Tx/Rx	Tx/Rx / Rx (transceiver modules)
Priority	Tx	Tx/Rx
Signal Threshold	-118	-80 ... -118 dBm

12 CONSIDERATIONS

12.1 EMI Interferers

The module is designed to be mounted inside a host device. The module is designed to withstand EMI even beyond type approval requirements. However, a small module which is integrated closely to modern high-speed electronics is bound to receive some interference.

To make a working integration, consider the following: EMI can enter the module in four ways:

- 1) Via the antenna (radiation from enclosure enters the antenna)
- 2) Radiated disturbances to the coaxial cable
- 3) Radiation from other electronics / cabling directly to the module
- 4) Conducting through the DTE interface (power, control and data lines).

Because the module is shielded and the DTE interface is filtered, the usually worst method of disturbance is via the antenna port, which is easily overlooked in design. Keep in mind that the radio module has a sensitivity of approx. -115 dBm (depending on mode of operation and speed etc.). While the module has an approx. 10 dB S/N requirement, this constitutes, that any signal entering the radio antenna on receive frequency on a level of < -125 dBm (-115 dBm - 10 dB), causes desensitization of the radio on that particular channel.

Example:

An interferer has a level of -100 dBm on the frequency 421 MHz. The radio will show an approximate sensitivity of -90 dB (-100 dBm+S/N requirement 10 dB) on 421 MHz.

Now consider that generic EMC requirements usually have pass/fail criteria of -57 dBm (if normalized to the surface of the device). **So, there is almost a 70 dB gap between generic EMC requirements and co-existence requirements between a high sensitivity narrowband radios.**

To avoid problems of co-existence a good design should apply:

- 1) EMI shielding in enclosure – ambient air interface
- 2) careful layout
- 3) shielding of all digital high-speed parts and cables
- 4) Have a clocking plan to avoid clock frequencies causing harmonics on the UHF band of interest.

Number one is to recognize this challenge and act upon it.

SATEL R&D can help in this by participating in design review of the host device, aiming to catch problems early in the design phase.

12.2 Electrostatic discharge

As the module is intended to be embedded in a host application, in a typical use case, the antenna port is the only port of the module directly interface with a surface or contact area subjected to Electrostatic Discharge (ESD). Thus, the antenna port is the only interface with high level ESD protection. The DTE port also features ESD protection diodes but is not designed to withstand similar performance as expected from standalone units with enclosures.

Consequently, the module should be subject to ESD handling precautions that typically apply to ESD sensitive components. Proper ESD handling and packaging procedures must be applied throughout the processing, handling and operation of any application that incorporates this module.

12.3 Using the device in unmanned high reliability applications

The module features software and hardware watchdogs which are incorporated inside the CPU. While we believe that this is a reliable method of keeping the module in operational condition, there are parts of the module that can't be monitored for proper operation to 100%. For example, the module chip has a firmware that resides in the chips RAM. The firmware can't be read back or reloaded, without interrupting reception. Hence the module can't reload this automatically by itself without causing breaks in communication. To avoid the module from ending up in a state where for example the module chip firmware is corrupted for example by ionizing radiation, it is recommended that the controlling system implements some form of watchdog function for the module. This can be done for example if the system knows that data should be received every second, and no data has been received for a minute – then do a module restart using the ENA_MOD pin or by issuing a restart command, or a cold boot by toggling VCC_IN low and high again.

12.4 Proposals for more reliable radio link

In case where the environment is challenging the following methods can be used for improving the transmission reliability:

- Forward Error Correction, FEC, is recommend using in challenging environment like urban areas.
- Directional antennas.
- Before building the radio link(s) it is highly recommend that the radio environment is measured to find out whether the radio environment is clean enough by using a spectrum analyzer or radio module's RSSI, Received Signal Strength Indication, value.
- Co-operation with the local authority to find out the optimum free radio channel.
 - If the channel is disturbed an external band-pass filter can be used for improving the filtering.
 - If at the adjacent channel is TDMA, Time Domain Multiple Access, it is recommended to use time slot for receiving which is not in synchronization with the TDMA radio transmission.
 - In Europe it is not recommended to use channels which are located near by the TETRA or television frequencies.

13 APPENDIX

13.1 Module dimensions

In the figure below is SATEL-TR300 with dimensions as millimeters.

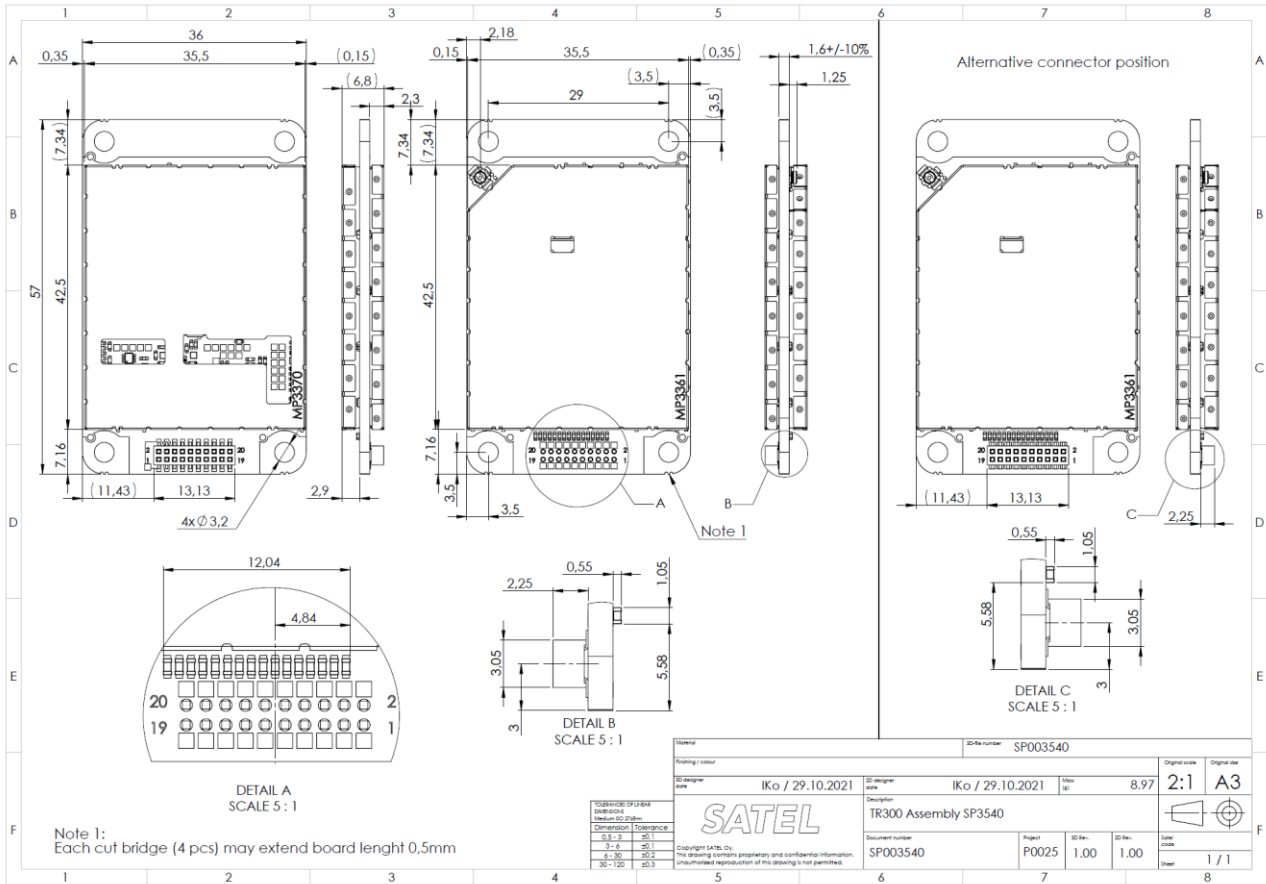

14 VERSION HISTORY

Version history:

Version:	Date:	Remarks:
0.1	10.02.2022	First draft.
0.2	09.06.2022	Added regional features chapter Removed changing frequency band chapter Updated SL command list annex information
0.3	06.07.2022	Added features to regional settings chapter
0.4	30.9.2022	Added transmitter call ID to regional settings chapter
0.5	03.11.2022	Added certification info to Japan certification process
0.6	12.12.2022	Configuration Manger info updated
0.7	14.12.2022	Technical specification values updated
0.8	16.12.2022	Updated page numbering etc
0.9	27.3.2023	FCC/IC text removed and MPE table added to regulatory information
1.0	15.6.2023	Multiple corrections
1.1	4.7.2024	Multiple corrections and additions
1.2	2.1.2025	Multiple corrections and additions