

SATEL

Mission-Critical Connectivity

SATEL-EASy+

YM6015, YM6055, YM6010, YM6050

SATEL-EASy+ 300

YM6030, YM6035, YM6060, YM6065

SATEL-EASy+ ETH

YM6070

User Manual

Version 1.42

IMPORTANT NOTICE

All rights to this manual are owned solely by SATEL Oy (referred to in this user guide as SATEL). All rights reserved. The copying of this manual (without the written permission from the owner) by printing, copying, recording or by any other means, or the full or partial translation of the manual to any other language, including all programming languages, using any electrical, mechanical, magnetic, optical, manual or other methods or devices is forbidden.

The software and product names as well as all copyrights relating to the software are the sole property of SATEL. Any transfer, licensing to a third party, leasing, renting, transportation, copying, editing, translating, modifying into another programming language or reverse engineering for any intent is forbidden without the written consent of SATEL.

SATEL reserves the right to change the technical specifications or functions of its products, or to discontinue the manufacture of any of its products or to discontinue the support of any of its products, without any written announcement and urges its customers to ensure, that the information at their disposal is valid.

SATEL products have not been designed, intended nor inspected to be used in any high error tolerance military-, aviation-, space-, marine- or any life depending/supporting medical or other similar applications unless it is clearly stated to be targeted to such special applications. Intended use to such applications which could lead to casualties, material losses or environmental damage is strictly prohibited. The manufacturer does not grant any kind of warranty including guarantees on suitability and applicability to these applications. Under no circumstances is the manufacturer or the developer of a software responsible for any possible damages caused by the use of the product.

Salon, FINLAND 2026

RESTRICTIONS ON USE – SATEL-EASy+ (403-473 MHz)

SATEL-EASy+ radio modems have been designed to operate on frequency ranges, the exact use of which differs from one region and/or country to another. The user of a radio modem must take care that the device is not operated without the permission of the local authorities on frequencies other than those specifically reserved and intended for use without a specific permit.

SATEL-EASy+ radio modems are allowed to be used in the following countries, either on licence free channels or on channels where the operation requires a licence. More detailed information is available at the local frequency management authority.

Countries*: AT, AU, BE, BG, CA, CH, CY, CZ, DE, DK, EE, ES, FI, FR, GB, GR, HR, HU, IE, IS, IT, LT, LU, LV, MT, NL, NO, PL, PT, RO, SE, SI, SK, TR, US

* Codes of the countries follow the ISO 3166-1-Alpha-2 standard

WARNING!

Users of radio modems in North America should be aware, that due to the allocation of the frequency band 406.0 – 406.1 MHz for government use only, the use of radio modem on this frequency band without a proper permit is strictly forbidden.

WARNING!

To be protected against all verified adverse effects the separation distance of at least 50 cm must be maintained between the antenna of this device and all persons.
In addition to comply with FCC and IC RF exposure compliance requirements, maximum antenna gain is 14 dBi. The device must not be co-located or operating in conjunction with any other antenna or transmitter.

Modification warning statement

Changes or modifications not expressly approved by the party responsible for compliance could void the user's authority to operate the equipment.

Class B digital device statement

Note: This equipment has been tested and found to comply with the limits for a Class B digital device, pursuant to Part 15 of the FCC Rules. These limits are designed to provide reasonable protection against harmful interference in a residential installation. This equipment generates

uses and can radiate radio frequency energy and, if not installed and used in accordance with the instructions, may cause harmful interference to radio communications. However, there is no guarantee that interference will not occur in particular installation. If this equipment does cause harmful interference to radio or television reception, which can be determined by turning the equipment off and on, the user is encouraged to try to correct the interference by one or more of the following measures:

- Reorient or relocate the receiving antenna
- Increase the separation between the equipment and receiver
- Connect the equipment into an outlet on a circuit different from that to which the receiver is connected
- Consult the dealer or an experienced radio/TV technician for help

RESTRICTIONS ON USE – SATEL-EASy+ 300 (320-380 MHz)

SATEL-EASy+ 300 radio modem has been designed to operate on 320-380 MHz, the exact use of which differs from one region and/or country to another. The user of a radio modem must take care that the said device is not operated without the permission of the local authorities on frequencies other than those specifically reserved and intended for use without a specific permit.

SATEL-EASy+ 300 is allowed to be used in the following countries. More detailed information is available at the local frequency management authority.

Countries*: AE, AT, AU, BE, BG, CH, CY, CZ, DE, DK, EE, ES, FI, FR, GB, GR, HU, HR, IE, IS, IT, KR, LT, LU, LV, MT, NL, NO, PL, PT, RO, SE, SI, SK, JP**

* Codes of the countries follow the ISO 3166-1-Alpha-2 standard

** See sections: Host integration and 6.12 Japan regional specific features

WARNING – RF Exposure!

To comply with RF exposure compliance requirements in Europe, maximum antenna gain is 12 dBi and a separation distance listed in a table below must be maintained between the antenna of this device and all persons.

G (dBi)	r / cm
0	20
4	32
6	40
8	50
10	63
12	79

MODIFICATION WARNING STATEMENT

Changes or modifications not expressly approved by the party responsible for compliance could void the user's authority to operate the equipment.

Class B digital device statement

Note: This equipment has been tested and found to comply with the limits for a Class B digital device, pursuant to Part 15 of the FCC Rules. These limits are designed to provide reasonable protection against harmful interference in a residential installation. This equipment generates uses and can radiate radio frequency energy and, if not installed and used in accordance with the instructions, may cause harmful interference to radio communications. However, there is no

guarantee that interference will not occur in particular installation. If this equipment does cause harmful interference to radio or television reception, which can be determined by turning the equipment off and on, the user is encouraged to try to correct the interference by one or more of the following measures:

- Reorient or relocate the receiving antenna
- Increase the separation between the equipment and receiver
- Connect the equipment into an outlet on a circuit different from that to which the receiver is connected
- Consult the dealer or an experienced radio/TV technician for help

PRODUCT CONFORMITY

Hereby, SATEL Oy declares that radio modems are in compliance with the essential requirements (radio performance, electromagnetic compatibility and electrical safety) and other relevant provisions of Directive 2014/53/EU. Therefore, the equipment is labelled with CE-marking.



TABLE OF CONTENTS

RESTRICTIONS ON USE – SATEL-EASY+ (403-473 MHZ)	2
RESTRICTIONS ON USE – SATEL-EASY+ 300 (320-380 MHZ)	4
PRODUCT CONFORMITY	6
TABLE OF CONTENTS	7
DESCRIPTION OF THE PRODUCT	13
WARRANTY AND SAFETY INSTRUCTIONS	14
1 NOTES FOR THE SATELLINE-3AS NMS USERS	15
1.1 How to add SATEL-EASy+ to SATELLINE-3AS NMS network	15
2 SATEL-EASY+ MECHANICAL DIMENSIONS	16
3 SATEL-EASY+ TECHNICAL SPECIFICATIONS	18
3.1 SATEL-EASy+ 403-473 MHz	18
3.2 SATEL-EASy+ 300 320-380 MHz	20
3.3 General for both variants.....	21
4 INTERFACE – CONNECTORS & LEDS	23
4.1 Antenna connector.....	23
4.2 Power supply.....	23
4.3 Serial ports (SATEL-EASy+)	24
4.4 LED indicators	24
4.5 D15 connector SATEL-EASy+	25
4.6 M8 power connector (SATEL-EASy+ ETH).....	26
4.7 M8 USB connector (SATEL-EASy+ ETH)	27

4.8	M8 Ethernet connector (SATEL-EASy+ ETH)	27
5	SERIAL INTERFACE	28
5.1	RS-232 interface (Port 1, Port 2)	29
5.2	RS-422 interface (Port 2)	29
5.3	RS-485 interface	30
5.4	Termination of RS-422/485 lines	30
5.5	Serial data format	31
5.6	Handshaking lines	31
5.6.1	CTS line	32
5.6.2	CD line	32
5.6.3	RTS line	33
5.6.4	DTR line.....	33
5.6.5	DSR line.....	33
5.7	Pause length	33
5.8	Data buffering	34
6	ETHERNET INTERFACE	35
6.1	TCP Server	35
6.2	TCP Client	35
6.3	UDP	35
6.4	Usage of data interfaces	35
6.5	Example TCP/IP configuration	36
7	USB INTERFACE	38
8	BLUETOOTH INTERFACE	39
8.1	Bluetooth Server	39
8.2	Bluetooth Client	39
9	RF INTERFACE	40

9.1	Transmitter	41
9.2	Receiver	42
9.3	Priority RX/TX.....	42
9.4	Forward Error Correction (FEC)	43
9.5	Error checking	43
9.5.1	SATELLINE-3AS NMS radio compatibility mode	43
9.5.2	SATELLINE-3AS mode	44
9.6	Air Encryption.....	44
9.7	TX delay	45
9.8	RX Delay.....	45
9.9	Add RSSI to data	46
9.10	Separate RX/TX-frequencies	46
9.11	Radio compatibility.....	46
9.11.1	Settings in Pacific Crest/TRIMTALK compatibility modes	47
9.11.2	Repeater function.....	49
9.11.3	Support for Local / Remote addresses	49
9.11.4	Transmission delays.....	50
9.12	Japan regional specific features.....	52
10	TEST MODES.....	53
10.1	Short block test	53
10.2	Long block test	53
11	SETTINGS	54
12	CONFIGURATION	60
12.1	Radio modem configuration	60
12.2	Radio network configuration	61
12.3	SATEL COMMAND	61
13	DISPLAY AND PUSH BUTTONS	62

13.1	LCD menu navigation	63
13.2	Push buttons	67
14	SL COMMANDS.....	68
14.1	Changing parameters using the SL COMMANDS	68
14.2	Command Mode	69
14.2.1	Entering to command mode - +++	69
14.2.2	Return to data mode - ---	69
15	CHANNEL LIST	71
16	REPEATER MODE AND ADDRESSING.....	73
16.1	Repeater	73
16.2	Addressing	74
16.2.1	Connection between two points	76
16.2.2	System of one base station and several substations.....	77
16.3	Using repeaters and addresses in the same system.....	77
16.3.1	System with several repeaters.....	78
16.3.2	Repeater chain using address pairs	79
16.3.3	Repeater chain using dual addressing	80
16.3.4	Redundant repeater chain	80
17	MESSAGE ROUTING	81
17.1	Introduction to Message Routing.....	81
17.1.1	Features of Message Routing	82
17.1.2	Limitations of Message Routing.....	82
17.1.3	Configuration of the Message Routing	82
17.1.4	Configuration of the protocol in Message Routing	85
17.2	Detailed description of Source Routing	86
17.2.1	Over-hop function in Source Routing.....	87
17.2.2	Network ID	88
18	NMS NETWORK MANAGEMENT SYSTEM	89
18.1	System components.....	89
18.2	NMS - Installation	89

18.3	NMS - Usage.....	90
18.4	NMS functionality	90
18.5	Requirements for the user system	91
18.6	Designing Systems and Networks.....	91
19	SOFTWARE FEATURE EXTENSIONS	92
19.1	AES256 encryption (YD0402)	92
19.2	SATEL NMS default config (YD0602)	92
20	INSTALLATION.....	93
20.1	Installation of the radio modem	93
20.1.1	Installation Requirements	94
20.1.2	Installation Parts.....	94
20.1.2.1	Installation Plate	94
20.1.2.2	Velcro tapes.....	95
20.1.3	DIN Installation Part.....	95
20.1.4	Grounding, using the housing.....	96
20.1.5	Grounding, using the installation plate.....	96
20.1.6	Grounding cable and screws.....	97
20.1.7	Grounding the antenna.....	97
20.2	Wiring SATEL-EASy+	98
20.2.1	RS-232 wiring - Port1 without handshaking	98
20.2.2	RS-232 wiring - Port1 and handshaking signals connected	98
20.2.3	RS-422 wiring.....	99
20.2.4	RS-485 wiring.....	99
20.2.5	Programing mode adapter	100
20.3	Antenna installation.....	100
20.3.1	Mobile equipment	100
20.3.2	Base stations	101
20.3.3	General antenna installation instructions	101
21	DESIGNING SYSTEMS.....	104
21.1	Factors affecting the quality and distance of the radio connection	104
21.2	Radio field strength	105
22	CHECK LIST	106

23 ACCESSORIES	107
24 RECYCLING ELECTRIC WASTE (WEEE)	108
25 APPENDIX A.....	109
26 APPENDIX B – DELAYS	110
26.1 Functional delays.....	110
26.2 Transmission related delays	110

DESCRIPTION OF THE PRODUCT

SATEL-EASy+ is a versatile transceiver radio modem that provides a compact and flexible solution for many different wireless applications. The key features include:

- 320-380 MHz / 403-473 MHz frequency range
- User selectable channel spacing 6.25 * / 12.5 / 20 / 25 kHz
- Compatible with the widely used SATELLINE-3AS radio modem family
- 403-473 MHz variants are compatible also with Pacific Crest-4FSK/GMSK/FST and TRIMTALK450s protocols
- Half duplex radio data transfer
- Over-the-air data rate with SATELLINE-3AS compatibility option (4FSK radio modulation):
 - 4800 bps @ 6.25 kHz channel spacing (3600 bps with FEC on)*
 - 9600 bps @ 12.5 kHz channel spacing (7200 bps with FEC on)
 - 9600 bps @ 20 kHz channel spacing (7200 bps with FEC on)
 - 19200 bps @ 25 kHz channel spacing (14400 bps with FEC on)
- Small current consumption, sleep modes
- Power level of the transmitter 10 mW...1 W
- RS-232 / RS422 / RS485 serial interface at 1200...115200 bps data rates
- LCD display and 4 push buttons (models with display)
- Easy configuration, no need to use external terminal to change the basic settings
- Monitoring of the signal (RSSI) or noise level and the voltage of the power supply
- LED indicators show the status information of the operations and functions.
- Routing/repeater functions
- Error correction (FEC)
- External command language (SL commands)

* Supported in SATEL-EASy+ 300 variants.

Please visit SATEL WEB pages for suitable software tools and to find additional information regarding SW tools: <https://www.satel.com/products/software/>

WARRANTY AND SAFETY INSTRUCTIONS

Read these safety instructions carefully before using the product:

- Warranty will be void, if the product is used in any way that is in contradiction with the instructions given in this manual, or if the radio modem housing has been opened or tampered with.
- The radio modem is only to be operated at frequencies allocated by local authorities, and without exceeding the given maximum allowed output power ratings. SATEL and its distributors are not responsible, if any products manufactured by it are used in unlawful ways.
- The devices mentioned in this manual are to be used only according to the instructions described in this manual. Faultless and safe operation of the devices can be guaranteed only if the transport, storage, operation and handling of the devices is appropriate. This also applies to the maintenance of the products.
- To prevent damage both the radio modem and any terminal devices must always be switched OFF before connecting or disconnecting the serial connection cable. It should be ascertained that different devices used have the same ground potential. Before connecting any power cables, the output voltage of the power supply should be checked.
- Any radio link can be susceptible to external interference and signal degradation by its nature. Because of that, the effects of possible interference mechanism and sufficient back-up schemes must be taken into account in the system design of the critical applications.

Following precautions and warnings should be considered while using the device:

- Do not open or modify the device by any means.
- Do not use the device to any other purpose that it is intended to.
- Do not connect the device to higher voltages than mentioned in this user guide.
- Do not attach the device directly to mains powered AC supply line. This will cause permanent damage to the device and could lead to an electrical shock.
- Avoid using the device in high/low temperatures and do not expose the device to direct sunlight.
- Use the device with a proper power source with adequate current output.
- Do not heat the device with any external source.
- Do not mechanically abuse the device over its limits or otherwise subject it to strong impacts, vibrations or shocks.

1 NOTES FOR THE SATELLINE-3AS NMS USERS

1.1 How to add SATEL-EASy+ to SATELLINE-3AS NMS network

Since the SATEL-EASy+ factory settings (serial port as well as the radio settings) are always the same, those should be set first as in the existing radio network to avoid conflicts. Note! SATEL-EASy+ ETH variant excluded.

Adding a new SATEL-EASy+ modem to SATELLINE-3AS NMS network:

Due to the settings of the SATEL-EASy+ modem, the new modem to network must be added in the SATEL NMS PC software Design menu with the function “Add modem using hardware” and then follow the requests in the to-do list.

Before this operation, it is recommended to check and adjust radio settings of the new SATEL-EASy+, e.g., channel width (spacing), frequency, FEC status.

As the default serial baud rate of SATELLINE-3AS NMS diagnostics port (port 2) is 9600 bps, it is recommended to use the same baud rate also with SATEL-EASy+ when adding it to an existing 3AS NMS radio network. When using this baud rate, the serial server advanced settings timeout must be set to 10000 ms. Otherwise, the connection between NMS PC and SATEL-EASy+ does not work properly.

When creating a new network with SATEL-EASy+, NMS port baud rate can be used 115200 bps. In this case the serial server timeout recommendation is 6000 ms.

SATEL Configuration Manager software:

SATEL-EASy+ does not support the terminal programming menu, therefore the modem settings, like serial ports, configuration for a device without a display are managed by SATEL

Configuration Manager SW. Connection to SATEL-EASy+ from the software is done by using Diagnostics (NMS) port of the radio, therefore CRS-NMS cable (YC0302) is required (Port 2 – NMS). Diagnostic (NMS) port default settings are: port 2, 115200 8N1.

Link to download SATEL Configuration Manager software: <https://www.satel.com/support-and-services/downloads/>

2 SATEL-EASy+ MECHANICAL DIMENSIONS

Following picture represents the SATEL-EASy+ mechanical external dimensions for device with and without the LCD display.

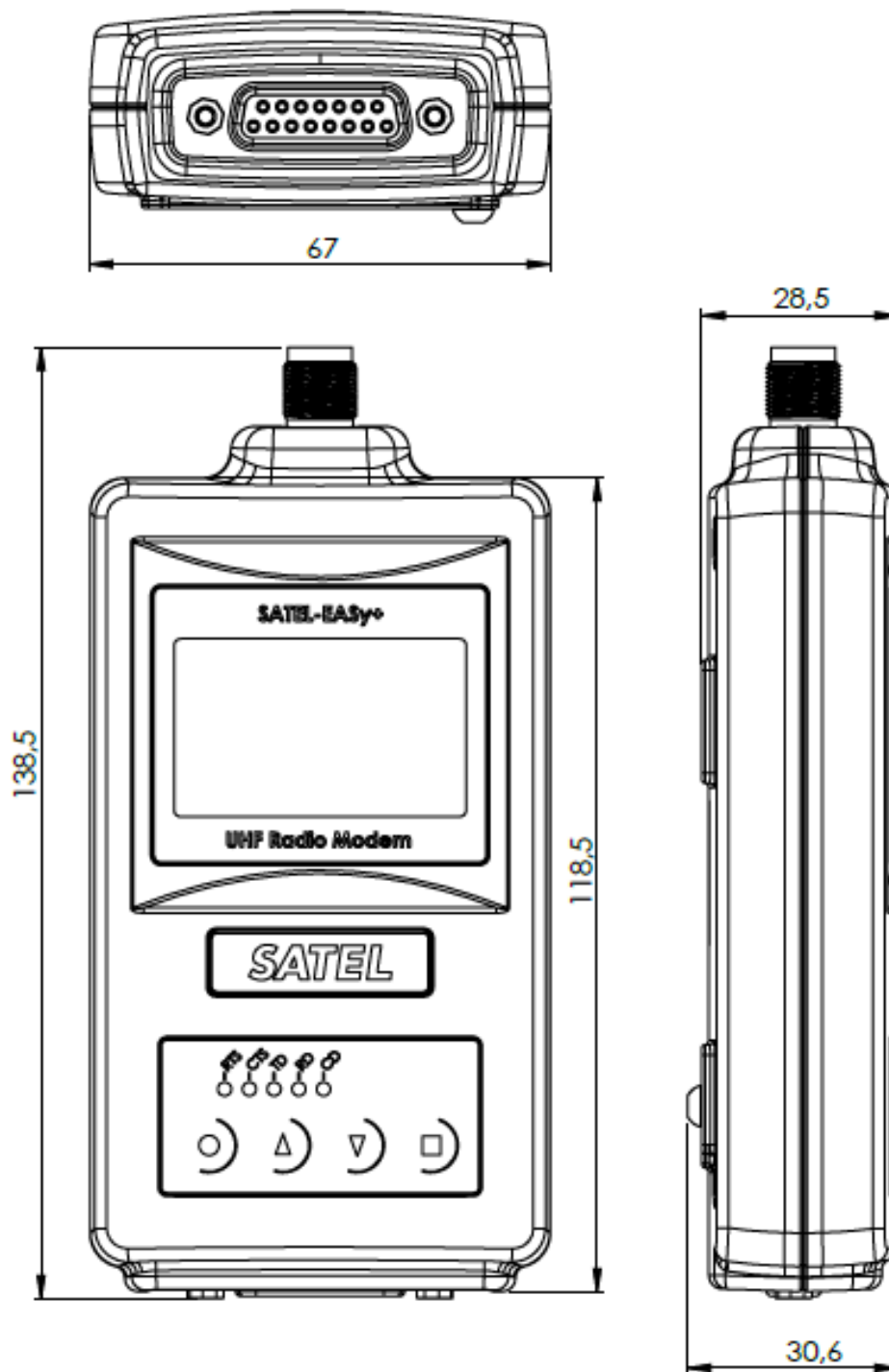

Figure 1.1 SATEL-EASy+ mechanical dimensions

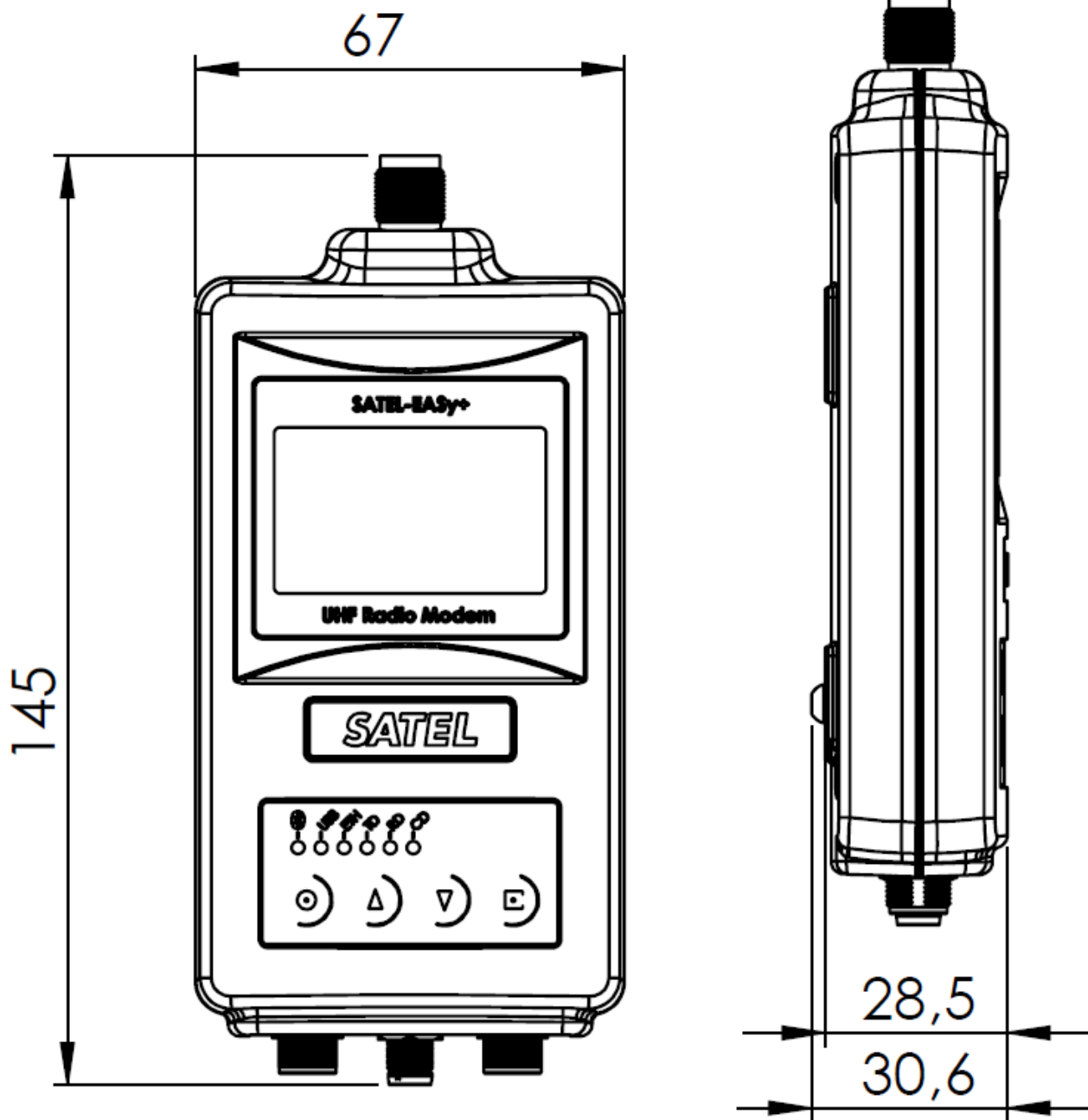

Figure 1.2 SATEL-EASy+ ETH mechanical dimensions

3 SATEL-EASy+ TECHNICAL SPECIFICATIONS

3.1 SATEL-EASy+ 403-473 MHz

Available models and product codes:

- YM6015 SATEL-EASy+, without display
- YM6055 SATEL-EASy+, with display
- YM6010 SATEL-EASy+, without display, with AES128/AES256 encryption support
- YM6050 SATEL-EASy+, with display, with AES128/AES256 encryption support
- YM6070 SATEL-EASy+ ETH, with display, with AES128/AES256 encryption support

	RECEIVER	TRANSMITTER	Note!
Frequency Range ³	403-473 MHz		See note 3
Tuning range	70 MHz		
Minimum RF Freq. Step	6.25 kHz		10 kHz @ 20 kHz channel spacing
Channel Bandwidth	12.5, 20, 25 kHz		
Frequency Stability	±0.5 ppm		-40°C...+85°C (Reference to +25°C)
Modulation	4-, 8-, 16-FSK, GMSK (Depending on protocol or compatibility mode)		Due to different radio interface protocol, 8-, 16-FSK modulations cannot be used under 3AS NMS routing protocol.
Maximum Receiver Input Power without Damage	+3 dBm		
Maximum Receiver Input Power without Transmission Errors	-10 dBm		4FSK, 25 kHz, FEC ON
Sensitivity ¹ BER = 10 ⁻²	typ. -113 dBm		4FSK, 25 kHz, FEC ON
	typ. -115 dBm		4FSK, 12.5 kHz, FEC ON
	typ. -111 dBm		8FSK, 25 kHz, FEC ON
	typ. -112 dBm		8FSK, 12.5 kHz, FEC ON
	typ. -102 dBm		16FSK, 25 kHz, FEC ON
	typ. -104 dBm		16FSK, 12.5 kHz, FEC ON
Blocking ¹ BER = 10 ⁻²	typ. -17 dBm		4FSK, 25 kHz, FEC ON
	typ. -20 dBm		4FSK, 12.5 kHz, FEC ON
	typ. -18 dBm		8FSK, 25 kHz, FEC ON
	typ. -17 dBm		8FSK, 12.5 kHz, FEC ON
	typ. -29 dBm		16FSK, 25 kHz, FEC ON
	typ. -25 dBm		16FSK, 12.5 kHz, FEC ON
Intermodulation Response Rejection ¹ BER = 10 ⁻²	typ. -35 dBm		4FSK, 25 kHz, FEC ON
	typ. -37 dBm		4FSK, 12.5 kHz, FEC ON
	typ. -36 dBm		8FSK, 25 kHz, FEC ON

	typ. -36 dBm		8FSK, 12.5 kHz, FEC ON
	typ. -44 dBm		16FSK, 25 kHz, FEC ON
	typ. -41 dBm		16FSK, 12.5 kHz, FEC ON
CO-Channel Rejection ¹ BER = 10 ⁻²	typ. 8 dB		4FSK, 25 kHz, FEC ON
	typ. 8 dB		4FSK, 12.5 kHz, FEC ON
	typ. 10 dB		8FSK, 25 kHz, FEC ON
	typ. 11 dB		8FSK, 12.5 kHz, FEC ON
	typ. 21 dB		16FSK, 25 kHz, FEC ON
	typ. 20 dB		16FSK, 12.5 kHz, FEC ON
Adjacent Channel Selectivity ¹ BER = 10 ⁻²	typ. -33 dBm		4FSK, 25 kHz, FEC ON
	typ. -36 dBm		4FSK, 12.5 kHz, FEC ON
	typ. -34 dBm		8FSK, 25 kHz, FEC ON
	typ. -34 dBm		8FSK, 12.5 kHz, FEC ON
	typ. -43 dBm		16FSK, 25 kHz, FEC ON
	typ. -40 dBm		16FSK, 12.5 kHz, FEC ON
Spurious Rejection	typ. -35 dBm		4/8/16FSK, 12.5 and 25 kHz, FEC ON
Transmitter Power		0.01, 0.02, 0.05, 0.1, 0.2, 0.5, 1 W	
Communication Mode	Half-Duplex		
Frequency Change Time	typ. 20 ms		Time required for switching from one RF frequency to another
Adjacent Channel Power		<-60 dBc	TX-mode, 12.5 and 25 kHz. Acc. to EN 300 113 v2.2.1
Carrier power stability		< ±1.5 dB	During transmission.

¹ According to EN 300 113 V2.2.1 measurement setup.

² Measured under normal ambient conditions, T_A = 25 °C. When the device is used in different environment, the results may change significantly. It is recommended to use external ESD protection in demanding conditions.

³ Firmware rejects 405.925...406.176 MHz frequencies (406.000–406.100 MHz when region setting is set to EU). The frequency band is reserved internationally for emergency transmitters as specified by FCC reference FCC 04-75.

BLUETOOTH	
Bluetooth features	Bluetooth v4.2 BR/EDR and BLE compliant, tested against v5.1
Radio features	Built-in Antenna TX Power: BR +11dBm, EDR +5dBm and LE +7dBm RX Sensitivity: -95dBm
Microcontroller	32-bit ARM Cortex-M4 core, 256/32 kB Flash/RAM memory
Environmental	Temperature range: -40°C to +85°C
Regulatory Certified	CE (EU), UKCA (UK), FCC (USA), ISED (Canada)

COMPLIANT WITH THE INTERNATIONAL STANDARDS	
RF-requirements	EN 300 113-2 / FCC CFR47 section 90
EMC-requirements	EN 301 489-1 & -5 (8 kV contact, 15 kV air discharge) *)
Safety Standard	IEC 62368-1
Immunity	EN 61000-4-3 (2006) (10 V/m)
Vibration	MIL-STD-202G Test condition D MIL-STD-202G Test condition F MIL-STD-202H-213

*) To ensure SATEL-EASy+ ETH compliance with European Union requirements, the product must use shielded cables (for example YC8163 M8 to USB-A, YC1759 M8 to RJ45, ETH cable and YC2227 M8 cable, 3-pin power cable).

3.2 SATEL-EASy+ 300 320-380 MHz

Available models and product codes:

- YM6030 SATEL-EASy+ 300, without display, with AES128/AES256 encryption support
- YM6035 SATEL-EASy+ 300, without display
- YM6060 SATEL-EASy+, with display, with AES128/AES256 encryption support
- YM6065 SATEL-EASy+, with display

	RECEIVER	TRANSMITTER	Note!
Frequency Range ³	320-380 MHz		See note 3
Tuning range	60 MHz		
Minimum RF Freq. Step	6.25 kHz		10 kHz @ 20 kHz channel spacing
Channel Bandwidth	6.25, 12.5, 20, 25 kHz		
Frequency Stability	±0.5 ppm		-40°C...+85°C (Reference to +25°C)
Modulation	4-, 8-, 16-FSK, GMSK (Depending on protocol or compatibility mode)		Due to different radio interface protocol, 8-, 16-FSK modulations cannot be used under 3AS NMS routing protocol.
Maximum Receiver Input Power without Damage	+3 dBm		
Maximum Receiver Input Power without Transmission Errors	-10 dBm		4FSK, 25 kHz, FEC ON
Sensitivity ¹ BER = 10 ⁻²	typ. -113 dBm		4FSK, 25 kHz, FEC ON
	typ. -115 dBm		4FSK, 12.5 kHz, FEC ON
	typ. -111 dBm		8FSK, 25 kHz, FEC ON
	typ. -112 dBm		8FSK, 12.5 kHz, FEC ON
	typ. -102 dBm		16FSK, 25 kHz, FEC ON
	typ. -104 dBm		16FSK, 12.5 kHz, FEC ON

Blocking ¹ BER = 10 ⁻²	typ. -17 dBm		4FSK, 25 kHz, FEC ON
	typ. -20 dBm		4FSK, 12.5 kHz, FEC ON
	typ. -18 dBm		8FSK, 25 kHz, FEC ON
	typ. -17 dBm		8FSK, 12.5 kHz, FEC ON
	typ. -29 dBm		16FSK, 25 kHz, FEC ON
	typ. -25 dBm		16FSK, 12.5 kHz, FEC ON
Intermodulation Response Rejection ¹ BER = 10 ⁻²	typ. -35 dBm		4FSK, 25 kHz, FEC ON
	typ. -37 dBm		4FSK, 12.5 kHz, FEC ON
	typ. -36 dBm		8FSK, 25 kHz, FEC ON
	typ. -36 dBm		8FSK, 12.5 kHz, FEC ON
	typ. -44 dBm		16FSK, 25 kHz, FEC ON
	typ. -41 dBm		16FSK, 12.5 kHz, FEC ON
CO-Channel Rejection ¹ BER = 10 ⁻²	typ. 8 dB		4FSK, 25 kHz, FEC ON
	typ. 8 dB		4FSK, 12.5 kHz, FEC ON
	typ. 10 dB		8FSK, 25 kHz, FEC ON
	typ. 11 dB		8FSK, 12.5 kHz, FEC ON
	typ. 21 dB		16FSK, 25 kHz, FEC ON
	typ. 20 dB		16FSK, 12.5 kHz, FEC ON

COMPLIANT WITH INTERNATIONAL STANDARDS	
RF-requirements	EN 300 113-2 / FCC CFR47 section 90
EMC-requirements	EN 301 489-1 & -5 (8 kV contact, 15 kV air discharge)
Safety Standard	IEC 62368-1
Immunity	EN 61000-4-3 (2006) (10 V/m)
Vibration	MIL-STD-202G Test condition D MIL-STD-202G Test condition F MIL-STD-202H-213

1 According to EN 300 113 V2.2.1 measurement setup.

2 Measured under normal ambient conditions, TA = 25 °C. When the device is used in different environment, the results may change significantly. It is recommended to use external ESD protection in demanding conditions.

3 Firmware rejects 405.925. 406.176 MHz frequencies. The frequency band is reserved internationally for emergency transmitters as specified by FCC reference FCC 04-75

3.3 General for both variants

DATA MODEM	
Electrical Interface	Port 1: RS-232, Port 2: RS-232/485/422 (SATEL-EASy+) Ethernet / Bluetooth / USB (SATEL-EASy+ ETH)
Interface Connector	D-15 female (SATEL-EASy+) M8-ETH, M8-USB, M8-power (SATEL-EASy+ ETH)
Data speed	Serial interface 1200 – 115200 bps (SATEL-EASy+) Ethernet 10/100 Mbps, USB2.0 (SATEL-EASy+ ETH)
Serial interface parameters	8N1, 8N2, 8E1, 8E2, 8O1, 8O2, 7N2, 7E1, 7E2, 7O1, 7O2

Data speed of Radio Interface	<u>4-FSK</u> 19200 bps (25 kHz channel) 9600 bps (12.5 or 20 kHz channel) 14400 bps (25 kHz channel with FEC on) 7200 bps (12.5 or 20 kHz channel with FEC on) <u>8-FSK</u> 28800 bps (25 kHz channel) 14400 bps (12.5 or 20 kHz channel) 19200 bps (25 kHz channel with FEC on) 9600 bps (12.5 or 20 kHz channel with FEC on) <u>16-FSK</u> 28800 bps (25 kHz channel with FEC on) 14400 bps (12.5 or 20 kHz channel with FEC on)
Air Interface Encryption	AES128 (default), AES256 (DRM option)
Data Format	Asynchronous data

GENERAL	
Operating voltage range	+7 ...+27.5 VDC (-15% / +20% *) **
Absolute MAX Voltage	+33 V (exceeding the value may damage the device)
Power Consumption	Receiver: MAX 2 W, typical <1.5 W @ 12 V Transmitter @1 W output: MAX 6 W, typical <5.5 W @ 12 V DTR OFF: MAX<50 mW, typical <10 mW @ 12 V
Temperature Ranges	-20 °C ... +55 °C Type Approval conditions -30 °C ... +70 °C Functional** -40 °C ... +85 °C Storage***
Vibration	≤ 25 G, up to 2 kHz sinusoidal
Antenna Connector	TNC female 50 Ohm
Construction	Aluminium housing
Size L x W x T / Weight	138.5 mm x 67 mm x 28.5 mm / < 350 g (SATEL-EASy+) 146 mm x 67 mm x 29 mm / < 350 g (SATEL-EASy+ ETH)

*Note: As a result of new revision of safety standard IEC600001, voltage range is marked to a label with tolerance limits.

** Using the device beyond this region the functionality cannot be guaranteed.

*** Recommended storage is at dry, room temperature

4 INTERFACE – CONNECTORS & LEDS

4.1 Antenna connector

All models have a single TNC female type antenna connector with impedance of 50 Ohm.

The antenna should always be connected when the power is on. Removing the antenna while the transmitter is on may damage the power amplifier inside the transmitter.

4.2 Power supply

The radio modem will consume electric power when connected to a power supply. The amount of power the modem consumes depends on the operational mode it functions. Highest power consumption is while transmitter is active, and output RF-power level is set to maximum. Even higher power is drawn from the power supply in a moment when the modem is being connected to a power supply. This so-called inrush current can be several times higher than normal current consumption but will last only few ten milliseconds. For proper operation it is crucial to assure that the power supply has output power rated to higher than the maximum power consumption of the device and that the power supply can handle short inrush currents properly.

SATEL-EASy+ is available in one operating voltage range: +7...+27.5 V_{DC} (-15% / +20%*).

*Note: As a result of new revision of safety standard IEC600001, voltage range is now marked with wider tolerance limits. Maximum and minimum operating voltages can be found from the Technical Specifications -chapter.

As an increased safety feature, it is recommended to add a fuse between the power supply and the modem. This ensures that both, the device and the power supply, are protected against over current situations. Recommended fuse size is 2 Amps.

Operating voltage range of SATEL-EASy+ is marked to a back of the housing as follows:

Freq: 403 - 473 MHz

7-27.5 VDC max. 6W

S/N:



Made by SATEL Oy - www.satel.com
Meriniitynkatu 17, 24100 SALO, Finland

4.3 Serial ports (SATEL-EASy+)

Before connecting DTE (Data Terminal Equipment) to the radio modem, please make sure that the configuration matches the physical interface (electrical characteristics, timing, direction and interpretation of signals). The radio modem contains two separate serial ports that are designated as **Port 1** and **Port 2**.

Port 1 - RS-232 (Port 1 ON is the default configuration)

Port 2 - Available options are:

RS-232/RS-485/RS-422 (RS232 is the default configuration)

4.4 LED indicators

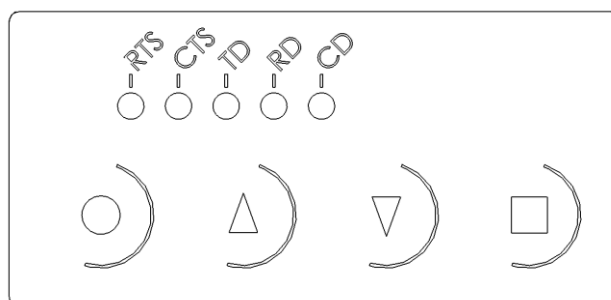

There are five (5) LED indicators on the front panel of the radio modem that indicate the status of the serial port and the radio interface:

LED	Indication	OFF	Red	Orange	Green
RTS	RTS-line status (D15 Pin 13)	Inactive	Active	-	-
CTS	CTS-line status (D15 Pin 6)	Inactive	Active	-	-
TD	TD-line status (D15 Pin 11) Indicates that the radio modem is receiving data via serial port.	No data	Data	-	Test Tx active
RD	RD-line status (D15 Pin 9) Indicates that the radio modem is sending data via serial port.	No data	Data	-	-
CD	Indicates the status of the radio interface. Note that the status of CD-line (D15 pin 2) may differ from the status of CD LED.	No signal	Transmitter is ON	Noise	Reception

SATEL-EASy+ ETH has 6 LED indicators: RTS and CRS are replaced by Bluetooth, USB and ETH. TD, RD and CD functionality is identical to SATEL-EASy+.

LED	Indication	OFF	Red	Blue	Green
Bluetooth	Bluetooth activity	Inactive	Blinking for connectable but not visible	Blinking for connectable and visible. Steady for connected	-
USB	USB connectivity	Cable not connected	Cable connected	-	USB serial port open
ETH	Ethernet activity led	Not connected	-	-	Steady for link up. Blinking for activity

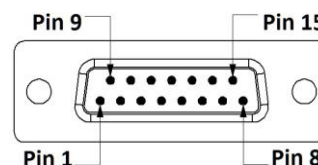

4.5 **D15 connector SATEL-EASy+**

SATEL-EASy+ radio modems: 15-PIN FEMALE D CONNECTOR PINOUT

I/O column below denotes the direction of the signal: "IN" is from DTE (Data Terminal Equipment) to the radio modem. "OUT" is from the radio modem to DTE.

PIN	NAME	I/O	LEVEL	EXPLANATION
1	DTR	IN	MAX +27.5V	Data Terminal Ready. This pin can be used to wake-up the radio modem from standby mode. >+3 VDC or not connected = ON, <+0.6 VDC = STANDBY. By default, this pin can be left unconnected.
2	Pin 2 has alternative functions depending on the Port2 configuration, see below.			
	CD	OUT	RS-232	Carrier Detect (if Port2 Interface mode is RS-232)
	A'	OUT IN/OUT	RS-422 RS-485	Port2 Receive Data positive (if Port2 Interface mode is RS-422) Shared input/output Data in RS-485 mode
	Pin 3 has alternative functions depending on the Port2 configuration, see below.			
3	RD2	OUT	RS-232	Port2 Receive Data (if Port2 Interface mode is RS-232)
	B'	OUT IN/OUT	RS-422 RS-485	Port2 Receive Data negative (if Port2 Interface mode is RS-422) Shared input/output Data in RS-485 mode
4	Pin 4 has alternative functions depending on the configuration, see below.			
	TD2	IN	RS-232	Port2 Transmit Data (if Port2 Interface mode is RS-232)
	A	IN	RS-422	Port2 Transmit Data positive (if Port2 Interface mode is RS-422)
5	Pin 5 has alternative functions depending on the hardware assembly, see below.			
	B	IN	RS-422	Port2 Transmit data negative

6	CTS	OUT	RS-232	Clear To Send. This signal indicates that the radio modem serial interface is ready to receive data from DTE. <i>Note*)</i>
7, 8	GND	-		Operating voltage ground / signal ground. Signal ground has a galvanic connection to the modem casing.
9	RD1	OUT	RS-232	Port1 Receive Data to DTE from the radio modem
10	DSR	OUT	RS-232	Data Set Ready. Indicates that the radio modem is ON.
11	TD1	IN	RS-232	Port1 Transmit Data from DTE to the radio modem.
12	MODE	IN	MAX +27.5V	<2VDC or connected to ground = Programming Mode >3VDC or not connected = Data Transfer Mode <i>Note**)</i>
13	RTS	IN	RS-232	Request To Send from DTE. <i>Note*)</i>
14, 15	V _b	-	See specs	Operating Voltage +7...+27.5 VDC

Note! Unused pins can be left unconnected.
Note)* RTS and CTS signals apply to the selected Data port only (Port1 or Port2).
*Note**)* Programming Mode disables radio interface operations and sets the modem to a serial port state: Data port 1 38400N81. By default, modem is Data Transfer Mode (pin 12 floating).

4.6 M8 power connector (SATEL-EASy+ ETH)

Device power supply connector is 3-pin M8 A-coded female. Power cable YC2227 available separately (M8 – open ends).

Pinout (device outside view)

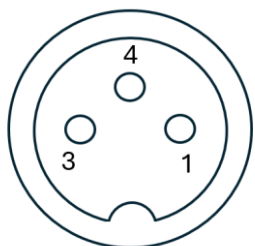
	Pin#	Signal	Wire color (YC2227)
	1	Power (7-27.5VDC)	Brown
	3	Ground	Blue
	4	Not connected	Black

4.7 M8 USB connector (SATEL-EASy+ ETH)

Device USB connector is 4-pin M8 A-coded male. USB cable YC8163 available separately (M8 to USB-A).

Pinout (device outside view)

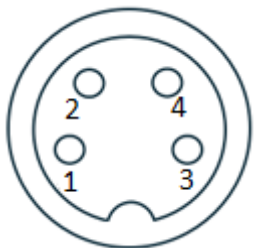
	Pin#	Signal	Wire Color (YC8163)
	1	VUSB	Brown
	2	D-	White
	4	D+	Black
	3	GND	Blue

4.8 M8 Ethernet connector (SATEL-EASy+ ETH)

- Device Ethernet connector is 4-pin M8 A-coded female. Ethernet cable YC1759 available separately (M8 to RJ-45). 4-wire straight-through cable (for 100Mbps or less).

Pinout (device outside view)

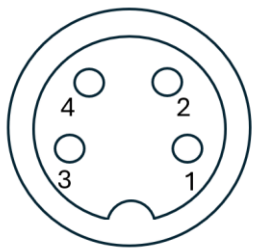
	Pin#	Signal	Wire color (YC1759)
	1	TX+	White-Orange
	2	RX+	White-Green
	4	TX-	Orange
	3	RX-	Green

5 SERIAL INTERFACE

The radio modem is referred to as DCE (Data Communication Equipment) whereas the device connected to it, typically a PLC or a PC, is referred to as DTE (Data Terminal Equipment). The 15-pin female 'D'-type connector of the radio modem contains the connections required to establish a data communication between the radio modem and DTE.

In order to transfer data, the physical interface between DCE and DTE must be compatible and properly configured. This chapter describes shortly the basics of the physical interface options, the related settings and the operation of the serial interface.

The radio modem contains two separate serial ports Port 1 and Port 2:

- One port can be selected for the system data at a time, one for NMS ("Diagnostics").
- Port1 is configured for data and ON-state by default.
- The physical interface of Port 1 is always RS-232.
- The physical interface of Port 2 depends on the selected settings.

SATEL-EASy+ Available serial port interfaces		
Serial Port	Physical interface	Note
Port 1	RS-232	Port 1 is always RS-232
Port 2	RS-232/RS-422/ RS-485	User selectable

The handshaking signals apply to the selected serial port (Port 1 or Port 2). The handshaking signals are CD (Carrier Detect), RTS (Ready To Send), CTS (Clear To Send), DSR (Data Set Ready) and DTR (Data Terminal Ready). The physical level of these signals is always RS-232. The wiring and cable connections are illustrated in chapter [Installation](#).

SATEL-EASy+ fixed interface parameters

PROGRAMMING MODE with using SL Command	Port 1 = according to the active settings Port 2 = according to the active settings
PROGRAMMING MODE with using programming pin (NARS-1F) switched = ON	Port 1 = 38400,8,N,1 NMS. Port 2 = 38400,8,N,1 NMS RS-232.
Error mode	Port 1 = 38400,8,N,1 NMS. Port 2 = 38400,8,N,1 NMS RS-232.

5.1 RS-232 interface (Port 1, Port 2)

RS-232 standard defines the method of transferring binary single-ended data serially between DTE and DCE. Although the standard defines the electrical characteristics, timing and meaning of the signals, as well as the pin out of connectors, it is applied in a multitude of slightly differing ways (e.g., different pin configurations). For this reason, different computers and peripherals are not necessarily directly compatible with each other.

RS-232 standard defines transmission lines, in which each single signal line level is referenced to a common ground level. When connecting equipment using RS-232 interface make sure that the equipment is connected sharing the same ground potential. Major differences in ground potentials may result to large current flow in the ground (GND) wire and may lead to a malfunction or damage the connected devices!

RS-232 has been designed for serial data transfer over short distances (usually less than 15 m). For longer distances, RS-422 or RS-485 is better suited in order to maintain the integrity of data.

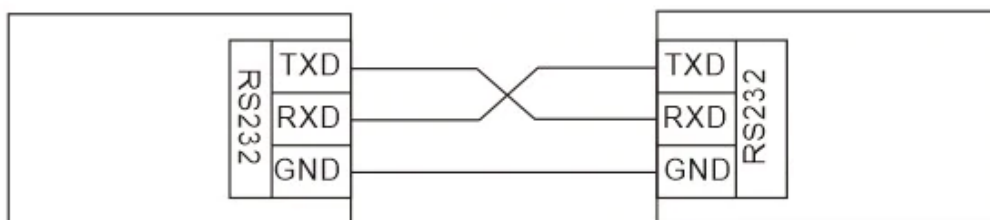

5.2 RS-422 interface (Port 2)

RS-422 standard defines a serial data transfer method, which is similar to the RS-232 standard. In RS-422 however, the signal lines are differential transmission lines. Differential transmission line is formed by using two signal wires together which are in opposite polarity to each other. Because the state of the signal is defined by the mutual voltage difference (hence the name differential), any common mode disturbances induced into the lines will cancel out. Transmission distance can be considerably longer than when using RS-232 type of connection, and distances of 1 km are possible.

As an example, let's examine the TX-signal: TX-signal will be transmitted using two lines (A and B). A logic "1" corresponds to a situation where the voltage on line A is greater than the voltage on line B. Correspondingly a logic "0" corresponds to a situation, where the voltage on line A is smaller than the voltage on line B.

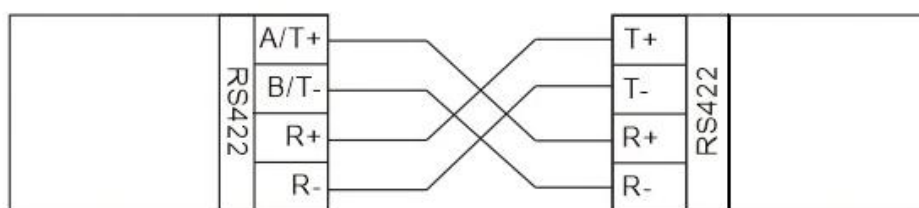

5.3 RS-485 interface

RS-485 is an extension of the RS-422 standard and enables the connection of more than two devices on to the same bus. Communication is half-duplex so there is only one cable pair compared to two when using the RS-422. One cable pair carry both, transmitter and receiver signals, but not at the same time. The RS-485 standard defines the electrical characteristics of the connections to prevent possible data contention states as well as cable shorts etc. from harming the devices themselves. RS485 can be set on by altering the user settings.

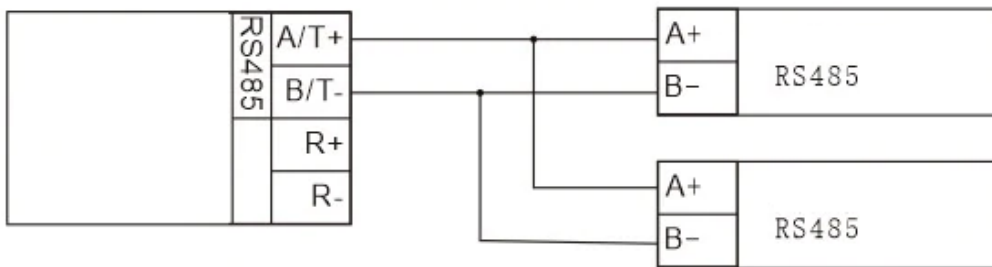

5.4 Termination of RS-422/485 lines

Each differential pair of wires is a transmission line. A transmission line must be terminated properly to prevent, or at least minimise, harmful reflections formed between the transmitting and receiving end of the transmission line. A common method of terminating RS-485 type of transmission line is to connect so-called termination resistor between the wires at both ends of the transmission line. Even when there are more than two devices on the same transmission line the termination resistors are needed only at the ends of the transmission line. The termination resistor must be selected so that its resistance matches the characteristic impedance of the transmission line as close as possible (typical values range from 100 to 120 Ohm). When using an RS-422 type of connection the termination resistor is connected only at each of the receiving ends. Termination resistors are particularly important when using long transmission lines and/or high data transfer speeds.

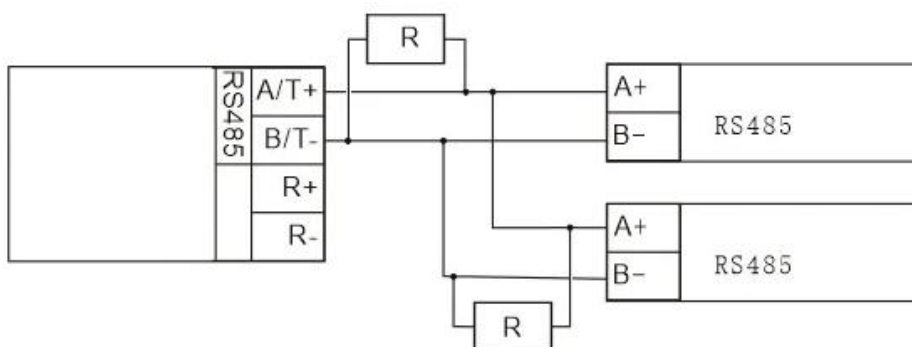

5.5 Serial data format

The serial interface uses an asynchronous data format. Any character to be transmitted on the serial line contains a start bit, the data bits (7 or 8 bits), an optional parity bit and one or two stop bits. Data bits are transmitted with the least significant bit first, the most significant bit last. For even parity, the number of 1's in the data plus the parity bit equals an even number. For odd parity, this sum is an odd number.

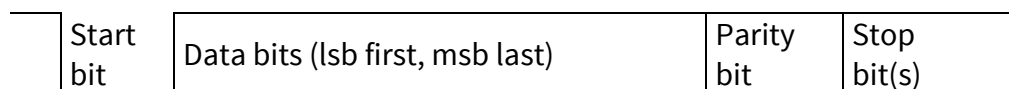

Example: The letter C (43 in hexadecimal, 01000011 in binary) is transmitted as shown in the table below when using 8-bit data length:

DATA FORMAT	CHARACTER	CHARACTER LENGTH
8 bits, no parity, 1 stop bit	0110000101	10 bits
8 bits, even parity, 1 stop bit	01100001011	11 bits
8 bits, odd parity, 1 stop bit	01100001001	11 bits
8 bits, no parity, 2 stop bits	01100001011	11 bits
8 bits, even parity, 2 stop bits	011000010111	12 bits
8 bits, odd parity, 2 stop bits	011000010011	12 bits

The overall length of characters (10, 11 or 12 bits) should be taken into account when calculating the data throughput capability of a system. A useful rule of thumb is that the transmission of one character will require roughly one millisecond (1ms) at 9600 bps.

The serial port settings of the radio modem and the terminal device connected to it must equal - otherwise errors will be introduced into the transferred data.

5.6 Handshaking lines

Handshaking signals can be used to control data transfer. For example, the radio modem can inform the DTE that the radio channel is busy, and that it is not allowed to initiate transmission.

A common way of using handshaking signals is to monitor the CTS-line and ignore the others. Usually, the terminal device is fast enough to handle the data received by the radio modem, so the use of RTS-line is not necessary.

Handshaking is not needed if the system protocol is designed to prevent collisions (data contention) by the use of polling, or if there is little traffic and also if there is no harm from occasional data contention situations (several radio modems try to transmit at the same time).

5.6.1 CTS line

CTS (Clear to Send) is a signal from the radio modem to the DTE. It indicates when the radio modem is ready to accept more data from the DTE. The options for CTS line are:

- Clear to Send - CTS line is set active when the radio modem is ready to accept data for transmission. CTS will shift into inactive state during data reception, and at the end of transmission. CTS shifts back into active state either when reception end or the radio modem has finished data transmission. CTS will also shift into inactive state when the transmit buffer is about to overflow i.e., there is more data coming in from the serial port than the radio is able to transmit.
- TX buffer state - CTS will shift into inactive state only if the radio modem's TX buffer is about to overflow. This typically happens when the transfer speed on the serial interface is greater than on the radio interface, and the size of transmitted messages is large.
- CTS line properties: Duty cycle, Always ON and RSSI Threshold are reserved for future purpose.

5.6.2 CD line

CD (Carrier Detect) is a signal from the radio modem to the DTE. It indicates when there is activity on the radio channel.

- RSSI-threshold - CD is active whenever a signal exceeding the level required for reception exists on the radio channel. It does not make any difference if the signal is an actual data transmission, a signal of a radio transmitter not belonging to the system, or even an interference signal. CD is also active when the radio modem itself is transmitting.

NOTE: Due to the shared pin configuration on D15 connector, CD signal is not available if Serial Port 2 is used for data transmission.

NOTE2: If Serial port 2 is in RS422/485 mode, CD signal is not available.

5.6.3 RTS line

The options for RTS-line are:

- Ignored - RTS-line status is ignored.
- Flow control - The radio modem transmits data to the terminal device only when the RTS-line is active. Non-active state of the RTS-line will force the radio modem to buffer the received data. This option is used if the terminal device is too slow to handle data received from the radio modem.

5.6.4 DTR line

DTR (Data Terminal Ready) has a special function in the radio modem - it can be used as an external ON/OFF switch for power saving purposes. When DTR-signal is LOW radio modem goes to low power saving mode where none of its functions are operational. When DTR signal is pulled HIGH radio modem will start up. During low power mode radio modem is reset. If the DTR pin is not connected i.e. floating, the radio modem is ON by default.

5.6.5 DSR line

DSR (Data Set Ready) is a signal from the radio modem to the DTE. It indicates that the radio modem is powered up.

5.7 Pause length

The modem recognises a pause on the serial line (a pause is defined as a time with no status changes on the RS-232 interface TD-line). The pause detection is used as criteria for:

- End of radio transmission - When the transmit buffer is empty and a pause is detected, the modem stops the transmission and will then change the radio to the receive mode.
- SL command recognition - For a SL command to be valid, a pause must be detected before the actual command character string.
- User address recognition - In order for the start character to be detected, a pause must precede it in transmission.

Traditionally, in asynchronous data communication, pauses have been used to separate serial messages from each other. However, the use of non-real-time operating systems (frequently used on PC-type hardware) often adds random pauses, which may result in the user data splitting into two or more separate radio transmissions. This may cause problems especially in the systems including repeater stations.

In order to match the operation of the radio modem to the user data, the Pause length parameter can be adjusted on the programming menu. It may have any value between 3 and 255 characters. The default value is 5 characters.

Notes:

The absolute time of Pause length is depending on the serial port settings. For example, 1 character is ~1.04 ms at 9600 bps / 8N1 (10 bits).

The maximum absolute time is always 170 ms independent from the value of the Pause length given in the set-up.

An increase in the Pause length increases the round-trip delay of the radio link correspondingly; this is due to the fact that the radio channel is occupied for the time of the Pause length after each transmission (the time it takes to detect a pause). If this is not acceptable, the TX delay setting may also be useful in special cases.

5.8 Data buffering

Whenever the radio modem is in Data Transfer Mode it monitors both the radio channel and the serial interface. When the terminal device starts data transmission the radio modem switches to transmission mode. At the beginning of each transmission a synchronisation signal is transmitted, and this signal is detected by another radio modem, which then switches into receive mode. During the transmission of the synchronisation signal the radio modem buffers data into its memory. Transmission ends when a pause is detected in serial line, and after all buffered data has been transmitted. When the serial interface speed is the same or slower than the speed of the radio interface, the internal transmit buffer memory cannot overflow. However, when the serial interface speed exceeds the speed of the radio interface, data will eventually fill transmit buffer memory. In this instance, it will take a moment after the terminal device has stopped transmission of data for the radio modem to empty the buffer and before the transmitter switches off. The maximum size of transmit buffer memory is two kilobytes (2 kB). If the terminal device does not follow the status of the CTS-line and transmits too much data to the radio modem, the buffer will be emptied, and the transmission is restarted.

In the receive mode, the buffer works principally in the above described way thus evening out differences in data transfer speeds. If the terminal device transmits data to a radio modem in receive mode, the data will go into transmit buffer memory. Transmission will start immediately when the radio channel is available. If TX delay setting is other than zero, then transmission is delayed until this value has elapsed.

6 ETHERNET INTERFACE

The SATEL-EASy+ ETH has one 4-wire 10/100Mbps Ethernet port. The device can have a static IPv4 address or use DHCP to fetch an address dynamically. The device will reply to ICMP ping messages.

When connected with Ethernet, SATEL-EASy+ ETH can support both TCP and UDP, and can act as a server or a client. The host will extract the data payload from the IP frames and transfer the data to the radio (assuming that frames hold data and not for example SL or NMS commands). Whole IP or TCP/IP packets will not be sent over the radio, so the device is not a router.

6.1 TCP Server

When configured as a TCP server, other devices can open a connection to SATEL-EASy+ ETH. SATEL-EASy+ ETH can have at least two sockets open with different ports at the same time: one for system data and another for configuration/NMS. These two sockets correspond to serial ports configured as Data or Diagnostics (NMS).

6.2 TCP Client

In TCP client mode, SATEL-EASy+ ETH device will attempt to form a TCP connection to the configured port and IP address. All data coming from the radio will be written to that connection, and data coming from that connection will be written to the radio.

The “Diagnostics” (NMS) TCP port will always be a server even in client mode, so that the device can be configured over IP in any mode.

6.3 UDP

Data transfer between Ethernet and radio interface in UDP/IP packages. “Listening Data Port” and “Destination Port” for system data can be configured separately (can be set same or different). “IP Mode” -parameter is irrelevant (Server/Client) in this mode. “Destination Address” -parameter needs to be defined, IP address for the data destination.

6.4 Usage of data interfaces

SATEL-EASy+ ETH has Ethernet, USB and Bluetooth interfaces that can all be set to be a data port, all connected to radio interface. When the device is receiving data from radio interface, this is a valid configuration. Received data from radio interface will be written out of all configured data ports.

Transmitting from multiple data ports at the same time is not recommended. If multiple data ports are configured, data should be written only through one although all can be used to receive.

6.5 Example TCP/IP configuration

Example configuration for TCP/IP in transparent radio data communication (no radio routing features used, TX/RX Addressing, Source Routing, NMS Routing).

The SATEL-EASy+ ETH may be configured to operate in two TCP roles: server or client.

- As a TCP server, the device waits for connections from other devices. The “Listening Data Port” port must be defined.
- As a TCP client, the device connects to other devices. “Destination Address” and “Destination Port” must be defined, IP address and port number of the target device.

For Modbus TCP protocol, port 502 is typically used. In both modes, data written to the IP connection will be written to the radio interface and vice versa. Only the data payload of the IP packet is sent over the radio.

Example configuration setup, Modbus TCP protocol:

- SCADA
 - IP address: 10.10.100.2/24
 - Target address and port: 10.10.100.1:502
 - IP address of the EASy+1
- EASy+1
 - IP Mode: TCP server
 - IP Address: 10.10.100.1/24
 - Listening Data port: 502
- EASy+2
 - IP Mode: TCP client
 - IP Address: 10.10.101.1/24
 - Destination address: 10.10.101.2
 - IP address of the PLC
 - Destination Port: 502
- PLC
 - IP address: 10.10.101.2/24
 - TCP port: 502

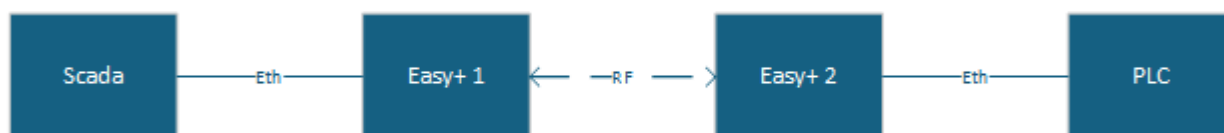

System dataflow:

1. SCADA opens TCP connection to EASy+1, after which it sends Modbus TCP data packages to EASy+1.
2. EASy+1 receives the data and transmits the data frame over the radio to EASy+2.

3. EASy+2 opens the TCP connection to PLC, after which it writes the data over TCP to the PLC.
4. Reply messages follow the same path in reverse via the opened TCP connections.

Radio layer data transmission is broadcast by default, thus the number of radios in the radio network is not limited. As the radio layer doesn't have collision avoidance by default, it is recommended to set the system IP data communication to synchronous mode in two-way data communication cases. Simultaneous radio layer transmissions will cause data losses.

For large radio networks where multiple radio repeater stations are needed, radio routing features (NMS Routing or Source Routing) are recommended. Free SATEL SW tools available for network design, configuration and monitoring with pre-configured network design templates. Please contact SATEL distributor or SATEL technical support for additional information.

7 USB INTERFACE

SATEL-EASy+ ETH, has USB 2.0 port. The radio modem acts as a USB Serial Device when connected to another device, for example a Windows PC.

The connected device needs to have CDC ACM (Abstract Control Model) USB driver, and it needs to be USB host device. This driver enables USB devices to emulate a standard COM port (UART) over USB.

The USB port is an NMS port (“Diagnostics”) by default for configuration and NMS monitoring. USB can be used also system data in Data -mode, just like RS-232 serial port. The speed of the port is not a configurable parameter, it is set by the USB host device that opens the connection. Serial settings 115200 8n1 are recommended, although the other parameters that are available for the RS-232 port are all supported. No handshaking lines are available on the USB connection.

8 BLUETOOTH INTERFACE

SATEL-EASy+ ETH offers Bluetooth connectivity. The Bluetooth version is 4.2 (tested against 5.1). Bluetooth uses an internal antenna that is inside the casing.

8.1 Bluetooth Server

When the device is a Bluetooth server, it offers a RFCOMM serial port that can be used for system data, configuring the device or for NMS (“Diagnostics”). Only paired devices can connect to the device, pairing needs to be enabled manually. The Bluetooth serial port offers the same functionality as the RS-232 serial port.

When in server mode, the device can also be configured with the SATEL COMMAND mobile app. Bluetooth Port Function must be set to “Data” (default).

8.2 Bluetooth Client

In client mode, the device can connect to other Bluetooth RFCOMM devices. The radio modem supports searching for other visible devices and connecting to them. Data received from the target device will be sent to the radio interface, and data received from the radio interface will be written to the target device.

9 RF INTERFACE

All modem types have a single TNC female type antenna connector with impedance of 50 Ohm.

SATEL-EASy+ offers the radio settings for user to select:

- Channel spacing: 25, 20, 12.5 or 6.25 kHz *
- Frequency can be any 6.25 kHz divisible frequency between 320...380 / 403...473 MHz in case the Channel Spacing is 25 or 12.5 kHz (for example 403.000, 403.006250, 403.012500 MHz)
- Frequency can be any 10.0 kHz divisible frequency between 320...380 / 403...473 MHz in case the Channel Spacing is 20 kHz (for example 403.000, 403.010, 403.020 MHz)

* Supported only in 320-380 MHz variants

The data speed of the radio interface depends on the radio channel spacing, see “TECHNICAL SPECIFICATIONS”, section Data speed of Radio Interface.

The data speed over-the-air is irrespective of the data speed of the serial interface. If the two differ from each other, the radio modem will buffer the data (max 2 kB) temporarily.

Please note that any communication link introduces an extra time delay called latency that affects the system performance. It is the minimum time experienced by the data between the moment when the data appears at the serial interface of the transmitting modem and the receiving modem. Appendix B presents measured transfer delays in details (SATEL-EASy+).

9.1 Transmitter

The output power of the transmitter is adjustable (see the table below for available values). The greatest allowable power depends on limits set by local authorities, which should not be exceeded under any circumstances. The output power of the transmitter should be set to the smallest possible level such that it still ensures error free connection under variable conditions. Excessively high output power levels used in short link spans can cause interferences and affect to the overall operation of the system.

Output power (mW)	Output power (dBm)	Available on 403-473 MHz
10 mW	+10 dBm	✓
20 mW	+13 dBm	✓
50 mW	+17 dBm	✓
100 mW	+20 dBm	✓
200 mW	+23 dBm	✓
500 mW	+27 dBm	✓
1000 mW	+30 dBm	✓

It is recommended to use the antenna (or a 50 Ohm attenuator) on the antenna connector while the transmitter is being used in order to prevent any damage to the internal electronics.

NOTE!

Setting the transmitter output power to such a level that exceeds the regulations set forth by local authorities is strictly forbidden. The setting and/or using of non-approved power levels may lead to prosecution. SATEL and its distributors are not responsible for any illegal use of its radio equipment and are not responsible in any way of any claims or penalties arising from the operation of its radio equipment in ways contradictory to local regulations and/or requirements and/or laws.

9.2 Receiver

The sensitivity of the receiver depends on the channel spacing of the radio modem (=data speed of the radio interface) and on the mode of the FEC (error correction).

The radio modem constantly measures the received signal strength (RSSI) of the receiver. The Signal Threshold setting determines the received signal level above which the search for the radio messages is active. If the threshold is set too low (the CD LED is ON constantly), receiver catches surrounding noise and constantly tries to receive messages. In such a case the actual data transmission might get missed and remain unnoticed. If the threshold is set too high, the weak data transmissions will be rejected although they could be otherwise receivable. Signal threshold should only be changed for a reason - for example in the following cases:

- Continuous low-level interference is present, and the desired signal is strong. In this case the signal threshold can be increased to prevent the modem from synchronising to the interfering signal(s) and /or possible noise.
- Maximum sensitivity should be achieved, and the desired signal is very weak. In this case the sensitivity could increase by decreasing Signal threshold. This type of situation is generally not desirable since the radio network has a poor signal strength condition. Bit errors and momentary loss of signals can be expected in this kind of a situation. Some data might be successfully transferred.

The radio modems equipped with an LCD display show the RSSI of the last received message in dBm units. The RSSI can be requested also locally by using a special SL command (SL@R?). The RSSI value is available 7s after receiving the message. After that the device starts to measure background noise floor ("n" indication on LCD UI).

9.3 Priority RX/TX

Priority setting selects the priority between reception and transmission. The setting can be changed via LCD UI (if device equipped with such), SL commands or configuration software. By default, transmission has higher priority than reception i.e., the default value is Priority TX.

Priority TX means that a terminal device attached to a radio modem decides the timing of the transmission. The transmitter is immediately switched on when the terminal device starts to output data. Should reception be in progress, the radio modem will stop it and change to a transmit state. There is no need to use any handshaking for the control of timing.

Priority RX means, that a radio modem tries to receive all data currently in the air. If a terminal device outputs data to be transmitted, it will be buffered. The radio modem will wait until the reception has stopped before transmitting the buffered data. This will result in timing slacks to the system but decreases the number of collisions on the air; this is particularly useful in systems based on multiple random accesses.

If the Repeater Function has been set on, priority setting is automatically switched to RX mode.

9.4 Forward Error Correction (FEC)

FEC improves the reliability of data transfer over the radio by adding additional correction information to the radio messages. Based on that information, the receiving radio modem will be able to correct erroneous bits provided the ratio of erroneous and correct bits is reasonable. However, the use of FEC decreases the data throughput because the amount of transmitted data increases about 30 % (see Appendix B). FEC should be used on long distance links and/or if the radio channel is “noisy” in other words suffering from interfering signals.

NOTE! All radio modems, which are to communicate with each other, must have the same setting for FEC (ON or OFF). If the transmitting radio modem and the receiving radio modem has different settings, data will not be received.

9.5 Error checking

When the error checking is switched on, the radio will add a checksum to the transmitted data. When the data is received, the checksum is verified before data is forwarded to the serial port. Options for error checking can be accessed either via SL commands or SATEL SW tools (<https://www.satel.com/products/software/>). Setting must be set equally for all radio modems in the same network. Error Check modes:

OFF (default setting). Received data is not verified at all. In practice, this is the fastest way to operate, because the data is given out from serial port immediately after it has been received. This is recommended method if the application protocol already includes error checking functions.

Other modes differentiate according to active protocol as follows:

9.5.1 SATELLINE-3AS NMS radio compatibility mode

Partial Error Check

This mode means that the radio modem checks the received data in small data blocks and sends the validated sub-messages to DTE. Once an error is detected, the rest of the message is ignored. That is, if an error takes place in the middle of a message, then the first part of the message is forwarded to the terminal device, but the data inside the erroneous sub-frame and the rest of the data will be ignored.

Full Error Check

In this mode the radio modem waits until the end of the reception and checks the whole received message before forwarding it to DTE. The additional time delay compared to No Error Check is roughly the time needed to transfer the user data message over the serial line.

9.5.2 SATELLINE-3AS mode

When the error checking is switched on, the radio will add a checksum to the transmitted data. When the data is received, the checksum is verified before data is forwarded to the serial port. Options for error checking can be accessed either via LCD UI, SL commands or SW tools (SATEL NETCO DEVICE or SATEL Configuration Manager). Error Check modes:

OFF (default setting). Received data is not verified at all. In practice, this is the fastest way to operate, because the data is given out from serial port immediately after it has been received. This is recommended method if the application protocol already includes error checking functions.

CRC-16 Full adds checksum characters accordingly at the end of the user data message. At the reception end the receiver receives first the whole package and if the checksum matches the data message is forwarded to the serial port. It is possible include the checksum into the received data in the serial line by setting the CRC-16 Full check to OFF state at the receiving radio(s). Additional data transfer delay will be added approximately according to the data packet size to the total transfer delay.

NOTE! This feature is designed for SATELLINE-3AS, SATEL-8FSK-1, SATEL-8FSK-2 and SATEL-16FSK-1 –radio compatibility modes.

9.6 Air Encryption

The product encrypts the data that is transmitted on the air interface with the listed encryption techniques:

- AES128
- AES256 (DRM Feature – see chapter “SOFTWARE FEATURE EXTENSIONS”)

Data security is often a concern when using radio communication. Bit encryption (CTR-mode) on the air-interface ensures privacy in the radio network. The principle of encryption in the radio path is to collect a certain amount of data to a shift register and manipulate it according to a certain rule. Every data packet is encrypted individually. Depending on the encryption type, the process of encryption adds 5-10ms delay in the data flow to each sent data packet (<5 characters in AES128 and <10 in AES256) and must be avoided in the cases where low latency is the most important requirement.

AES is open-source software from public domain. Author: Brian Gladman (U.K). The CTR-mode is SATEL’s in-house implementation.

The models supporting this feature and encryption level can be viewed in SATEL WEB sites at www.satel.com/products/. The radio models that do not support the encryption feature are compatible with the radio models with the encryption when the feature is disabled. **It is not possible to update/change the models NOT supporting the encryption to support this feature in the field.** The factory default value for the encryption feature is OFF state. The setting state with the static, distributed encryption keys must be set equally to the radios in the same radio network.

Please contact SATEL for more detailed information regarding the radio network compatibility settings in radio network between different models (channel width, radio frequency etc.).

The encryption password key is generated by using Main and Aux –keys plus in the beginning of the data packet transferred changing 32/64-bit string. It is mandatory to insert both information keys with the mentioned length keys.

Options for generating the encryption keys are:

- Manually via terminal connection:
 - o SL commands
- Automatically with password via SATEL SW tools (generates automatically the Main and Aux keys)

It is recommended to set up a radio network with encryption enabled by using only one selected configuration way. The equivalency of the encryption keys between radio modems can be verified from the Key Hash –information field. Last 4 marks indicates the equivalency [0-9, A-F].

NOTE! The encryption is designed for SATELLINE-3AS, SATEL-8FSK-1, SATEL-8FSK-2, SATEL-16FSK-1 and SATELLINE 3AS NMS –radio compatibility modes

9.7 TX delay

The radio modem can be configured to delay the beginning of a radio transmission by 1...65000 ms. The function can be used to prevent packet contention in a system, where all substations would otherwise answer a poll of a base-station simultaneously. During this delay data sent to the radio modem is buffered. Even when the priority setting is "RX", the radio modem is prevented to change over to the receiving mode during the period of the TX delay. If TX delay is not needed, its value should be set to 0 ms.

9.8 RX Delay

The radio modem can be configured to delay the beginning of a data reception (RD) by 0...255 ms. Radio sets 10 ms delay automatically if RS485 is used. Default: 0 ms.

9.9 Add RSSI to data

RSSI info "\02RSSI:-nnn dBm\03" will be concatenated to the end of serial port messages, nnn is three digit decimal number.

9.10 Separate RX/TX-frequencies

Modem can transmit (TX-frequency) and receive (RX-frequency) on separate frequencies. The switch between the frequencies introduces an extra 20 ms delay in the data transfer that must be taken account when designing the system.

9.11 Radio compatibility

SATEL provides several radio compatibility modes:
for selecting the optimum radio solution that fits the application
for enabling the interoperability between devices made by different manufacturers

SATEL-EASy+ supports the original SATEL radio compatibility modes:

- SATELLINE-3AS (4FSK, FEC ON/OFF is selected by the separate FEC setting) (option 0)
- SATEL-8FSK-1 (8FSK/FEC OFF) (option 20)
- SATEL-8FSK-2 (8FSK/FEC ON) (option 21)
- SATEL-16FSK-1 (16FSK/FEC ON) (option 22)
- SATELLINE-2ASxE legacy mode (option 6)

Additional to the native SATEL radio compatibility modes, also the following radio compatibility modes are supported by the 403 - 473 MHz frequency band product variants.

Pacific Crest compatible modes:

- PacCrest-4FSK FEC ON/Scrambling ON (option 1)
- PacCrest-4FSK FEC OFF/Scrambling ON (option 23)
- PacCrest-4FSK FEC OFF/Scrambling OFF (option 26)
- PacCrest-4FSK FEC ON/Scrambling OFF (option 28)
- PacCrest-GMSK FEC ON/Scrambling ON (option 2)
- PacCrest-GMSK FEC OFF/Scrambling ON (option 24)
- PacCrest-GMSK FEC OFF/Scrambling OFF (option 27)
- PacCrest-GMSK FEC ON/Scrambling OFF (option 29)
- PacCrest-FST 4FSK/FEC ON (option 5)
- PacCrest-FST 4FSK/FEC OFF (option 25)
- PacCrest-GMSK FEC ON, Scrambling ON, 4800 bps, 25 kHz (option 16)
- PacCrest-GMSK FEC OFF, Scrambling ON, 4800 bps, 25 kHz (option 17)
- PacCrest-GMSK FEC OFF, Scrambler OFF, 4800 bps, 25 kHz (option 18)
- PacCrest-GMSK FEC ON, Scrambler OFF, 4800 bps, 25 kHz (option 19)

Trimble compatible modes:

- TrimTalk450s(P) GMSK, Rx fitted to PacCrest transmitters (option 3)
- TrimTalk450s(T) GMSK, Rx fitted to Trimble transmitters (option 4)
- TrimTalk v1, GMSK, 8/16 kbps (option 30)
- TrimTalk 4800 bps, 25 kHz (option 31)
- Trimmark3 (option 12)

SOUTH (option 8)

RTCM SC135 modes – these are based on RTCM (Radio Technical Commission for Maritime Services) standard 13500.1 on Radio Layer for Real-Time DGNS Applications.

- RTCM SC135 1 (25 kHz, FEC ON) (option 34)
- RTCM SC135 2 (12.5 kHz, FEC ON) (option 35)
- RTCM SC135 3 (25 kHz, FEC OFF) (option 36)
- RTCM SC135 4 (12.5 kHz FEC OFF) (option 37)

Notes:

Supported compatibility options may vary depending on the model and factory configuration. All radio modems of a system must have identical FEC (ON or OFF) and Scrambling (ON or OFF) settings.

The implementation of the non-native radio compatibility options is based on the reference measurements and the available public data of the following radio modems manufactured by Pacific Crest Corporation: ADL, RFM96W, PDL HPB, PDL LPB.

TRIMTALK is a trademark of Trimble Navigation Ltd.

SOUTH GDL is a trademark of SOUTH Surveying & Mapping Instrument Co., Ltd.

The wanted radio compatibility mode can be selected by using:

- LCD user interface
- SATEL SW tools
- SL command SL@S (see chapter *SL commands*)

9.11.1 Settings in Pacific Crest/TRIMTALK compatibility modes

To use the Pacific Crest/TRIMTALK modes implemented in SATEL radios:

PACIFIC CREST modems must have:

- Protocol Mode
- Transparent w/EOT Timeout (when using Pacific Crest modulations)
- TrimTalk 450s (when using TRIMTALK GMSK modulation)
- Modulation Type depends on the system
- GMSK (default, always selected when using TRIMTALK 450s mode)
- 4-Level-FSK
- FEC = ON/OFF

- Scrambling = ON/OFF
- Data Security Code set to = 0 (=not used)
- Local Address= 0...254 (0 by default)

Pacific Crest modems receive messages from SATELLINE modems that have their TX1 address matching the Local Address.

Remote address=0...255 (255 by default, that is the broadcast address to be received by all). SATEL modems receive the message from a Pacific Crest radio, provided their RX1 address matches the Remote Address of a Pacific Crest transmitter (or if the message has the broadcast address 255).

SATEL modems must have the following key settings:

- FEC OFF (because the FEC here means SATEL 3AS FEC, not Pacific Crest/TRIMTALK FEC)
- Error check OFF
- Error Check mode OFF
- Radio Compatibility Option according to the list (setting dependent)

When TX address is selected ON, then TX1 address is used like PDL Remote address that is the destination address for the transmitted messages. Default value is 0x00FF (=255) (note the hexadecimal format of the setting).

When RX Address is selected ON, then RX1 address is used like PDL Local address. Default value is 0x0000 (=0) (note the hexadecimal format of the setting).

Addresses are NOT applicable in TRIMTALK 450s mode so SATEL modems must have their RX/TX addresses OFF with Option3.

The configuration tools and settings are different between SATEL and Pacific Crest modems: Pacific Crest modems are configured via the serial port using PDLCONF Windows™ program that sends binary control messages to the serial port of the modem.

SATEL-EASy+ radio modems are configured via the serial port using SL commands or SATEL SW tools.

The table below shows the analogy of settings between Pacific Crest and SATEL radio modems.

Pacific Crest setting	Corresponding SATEL setting
Identification: Owner	not implemented
Identification: Channel Bandwidth	Channel spacing
Identification: RF Power	TX power
Radio Link: Channel Selection Type (Manual)	Radio frequency
Radio Link: Current Channel	Radio frequency
Radio Link: Link Rate	Radio compatibility mode and channel spacing determine the link rate
Radio Link:Modulation Mode	Radio compatibility
Radio Link:Scrambling	ON by default
Radio Link:Transmit Retries	not implemented

Radio Link:TX ACK Timeout	not implemented
Radio Link:Csma Monitoring	Priority (RX=ON, TX=OFF) Default: TX
Radio Link: AutoBase/AutoRover	not implemented
Radio Link:Digisquelch	Signal threshold
Radio Link:Forward Error Correction	ON by default Note: SATEL-EASy+ FEC must be OFF!
Radio Link:Local Address (0 by default)	Primary RX address (RX1) (OFF by default)
Radio Link:Remote Address (255 by default)	Primary TX address (TX1) (OFF by default)
Serial Interface:Protocol Mode	Radio compatibility
Serial Interface:BREAK to Command	not implemented
Serial Interface:Modem Enable: Yes	not applicable
Serial Interface:Soft Break Enable	not implemented
Serial Interface:EOT value (in 0.01s units)	Pause length (in serial port byte intervals)
Serial Interface:Digipeater Delay	not implemented
Serial Interface:Local Node Repeater	not implemented
Frequency Table	Radio frequency
Data Security Code (must be 0=not used)	not implemented
<p>Potential conflicts: FEC setting applies only to the SATELLINE-3AS mode, the other radio compatibility modes have their own FEC bindings (although some previous or special firmware versions differ in the way FEC setting is handled - in case of doubt please contact technical support) Error check and Full CRC16 check must be OFF in SATEL modem SATEL RX/TX addressing does not use ARQ scheme like Pacific Crest radios.</p>	

9.11.2 Repeater function

The implemented Pacific Crest/TRIMTALK modes support also the repeater function. The repeater function is configured either by using the SL commands:

- "SL@M=R" (Repeater ON)
- "SL@M=O" (Repeater OFF)

or by selecting Repeater OFF/ON in the SATEL SW tools.

Note 1. If error correction is ON (FEC ON) and TRIMTALK mode is activated by using "SL@S=3" command, the firmware automatically switches SATEL FEC OFF temporarily, and turns it back at the mode return.

9.11.3 Support for Local / Remote addresses

If the modem has TX address ON then primary TX address is handled in the same way as Remote address in Pacific Crest PDL modems. The default value is 0x00FF (255 in decimal format) i.e. the broadcast address.

If the modem has RX address ON then primary RX address is handled in the same way as PDL Local address in Pacific Crest PDL modems. The default value is 0x0000 (0 in decimal format). SATEL modem needs to have TX Delay 50ms or more in order to avoid messages from colliding in case it is to be placed in a Pacific Crest system that uses addressing and acknowledging scheme.

In case only broadcast messages are used (like in RTK applications) there is usually no need for TX Delay, except if the transfer delays identical to Pacific Crest modems are preferred – in such cases an appropriate value of TX Delay is 34 ms.

Note 1. SATEL-modems do not support Pacific Crest retransmit/acknowledge scheme. However, that has no effect in RTK applications because they utilize only broadcast messages.

9.11.4 Transmission delays

The original SATELLINE-3AS is the fastest mode – the transfer delays are presented Appendix B. In the PacCrest-4FSK, PacCrest-GMSK and Trimtalk450s modes the whole message is first read from the serial port. The end of the message is detected when there is a pause in data. After that data is framed and transmitted over the radio. Likewise, the reception is done fully before outputting the message to the serial port.

Symbol rates of the compatibility modes		
The actual raw data rate is appr. 2/3 of the symbol rate.		
Compatibility mode	Symbol rate on 12.5 kHz channel	Symbol rate on 25 kHz channel
PacCrest 4FSK	9600 bps	19200 bps
PacCrest GMSK	4800 bps	9600 bps
Trimtalk450s	4800 bps	9600 bps
PacCrest FST	9600 bps	19200 bps

The typical latency vs. the size of a message is shown in the tables below for each radio compatibility mode with SATEL-EASy+. The delays are measured from the end of transmitted data to the end of received data on the serial interface.

Pacific Crest 4FSK mode on 12.5 kHz channel - Transfer delays				
Bps	1 byte	10 bytes	100 bytes	500 bytes
9600	74 ms	82 ms	302 ms	1293 ms
19200	73 ms	77 ms	249 ms	1031 ms
38400	72 ms	74 ms	222 ms	900 ms

Pacific Crest 4FSK mode on 25 kHz channel - Transfer delays				
Bps	1 byte	10 bytes	100 bytes	500 bytes
9600	43 ms	51 ms	208 ms	911 ms

19200	41 ms	46 ms	155 ms	650 ms
38400	39 ms	43 ms	127 ms	519 ms

Pacific Crest GMSK mode on 12.5 kHz channel - Transfer delays				
Bps	1 byte	10 bytes	100 bytes	500 bytes
9600	93 ms	101 ms	445 ms	2011 ms
19200	91 ms	97 ms	393 ms	1750 ms
38400	91 ms	92 ms	366 ms	1619 ms

Pacific Crest GMSK mode on 25 kHz channel - Transfer delays				
Bps	1 byte	10 bytes	100 bytes	500 bytes
9600	52 ms	62 ms	281 ms	1272 ms
19200	50 ms	55 ms	226 ms	1009 ms
38400	48 ms	51 ms	198 ms	878 ms

Trimtalk450s modes on 12.5 kHz channel - Transfer delays				
Bps	1 byte	10 bytes	100 bytes	500 bytes
9600	153 ms	177 ms	421 ms	1505 ms
19200	151 ms	172 ms	368 ms	1244 ms
38400	151 ms	168 ms	341 ms	1113 ms

Trimtalk450s modes on 25 kHz channel - Transfer delays				
Bps	1 byte	10 bytes	100 bytes	500 bytes
9600	82 ms	98 ms	267 ms	1017 ms
19200	80 ms	93 ms	215 ms	756 ms
38400	79 ms	89 ms	187 ms	625 ms

Radio compatibility Option 5 - Pacific Crest FST on 12.5 kHz channel				
Bps	1 byte	10 bytes	100 bytes	500 bytes
9600	47 ms	71 ms	261 ms	1145 ms
19200	45 ms	64 ms	207 ms	883 ms
38400	48 ms	65 ms	184 ms	756 ms

Radio compatibility Option 5 - Pacific Crest FST on 25 kHz channel				
Bps	1 byte	10 bytes	100 bytes	500 bytes
9600	31 ms	48 ms	190 ms	840 ms
19200	29 ms	41 ms	136 ms	578 ms
38400	28 ms	38 ms	109 ms	447 ms

9.12 Japan regional specific features

Modem can transmit (TX-frequency) and receive (RX-frequency) on separate frequencies. The switch between the frequencies introduces an extra 20 ms delay in the data transfer that must be taken account when designing the system.

Carrier Sense feature

Carrier sense feature is intended to use with certain region codes to achieve country specific RF specifications.

This feature works only with region codes where it is required, e.g., with Japan region code, to prevent device to transmit if it senses another signal in current channel to be stronger than given threshold before going to transmit state. When transmit is prevent, all buffered data is discarded.

Carrier sense threshold is adjustable (see SL commands) with range -60 ... -117 dBm. Value -118 dBm will turn this feature OFF.

Detailed SL commands required for carrier sense can be found in SL commands list.

Transmit time limitation

This feature is used to limit transmit time in certain region codes to achieve country specific transmitter time limitations, defined in RF specifications.

E.g., Japan region time limit will be five (5) minutes. If time limit was reached, transmitter is prevented to transmit for one (1) minute. Receiver will work normally within this time.

Transmitter Call ID

This feature works only with region codes where it is required, e.g., with Japan region code. Transmitter Call ID means that the modem sends a transmission ID with each transmission. The transmit ID is a 9-character identifier that is unique for each device.

Transmit ID Call sign is configured using a SATEL SL-command

- a) Set the transmitter Call ID with the command SL%CID=<max. 9 digit>
- b) Transmitter Call ID query with the command SL%CID?

Detailed SL commands description for transmitter Call Id can be found in SL commands list. Please contact SATEL Oy for latest SL commands list.

10 TEST MODES

The radio modem can be switched to a Test Mode in which it will send test messages to the radio channel. Test messages can be utilized for example when directing antennas during system installation. The transmitting radio modem needs only a power supply and an antenna in the test mode but no external terminal device.

If the test mode has been set ON, the radio modem starts to transmit test messages immediately after a reset or a power-up. Test messages are treated as normal data at the receiver side. The recommended data speed at the serial port of the receiving radio modem is 38400 bps @ 25 kHz radio channel or 19200 bps @ 12.5 kHz.

The test modes are designed for SATELLINE-3AS, SATEL-8FSK-1, SATEL-8FSK-2, and SATEL-16FSK-1 radio compatibility modes.

10.1 Short block test

In this test mode the radio modem sends a short test message that is preceded by a consecutive number and terminated by the Carriage Return and Line Feed characters. The test messages are repeated continuously at 1 second intervals. The short block test is suitable for running radio link tests. Reception of data can be monitored using a suitable terminal program.

Example of short data blocks:

```
00 This is a test line of SATELLINE-3AS radio modem
01 This is a test line of SATELLINE-3AS radio modem
```

10.2 Long block test

In this test mode the radio modem transmits a test message continuously for 50 s. After 10 s break the test transmission is started again. The transmission sequence is repeated continuously. The long block test can be used in order to measure the transmitter output power, standing wave ratio (SWR) of the antenna system or RSSI (Received Signal Strength Indicator) level at the receiver stations. RSSI can be monitored easily on the LCD display of the receiving modem or by using SL command "SL@R?".

Example of a long data blocks:

```
99 This is a long test line of SATELLINE-3AS radio modem
00 This is a long test line of SATELLINE-3AS radio modem
```

Note1. Green TD led indicates active test mode.

Note2. Remember to set the test mode OFF before starting the normal data transfer.

Note3. Message Routing must be disabled prior to setting the Test mode ON.

11 SETTINGS

List of settings	
Setting	Description and value range
TX frequency	<p>The radio frequency of the transmitter</p> <ul style="list-style-type: none"> • less than frequency band upper limits • more than frequency band lower limits • divisible by 6.250 kHz (if ch. spacing is 6.25, 12.5 or 25 kHz) • divisible by 10 kHz (if channel spacing is 20 kHz) <p>Default value: 350.000 or 438.000 MHz</p>
RX frequency	<p>The radio frequency of the receiver</p> <ul style="list-style-type: none"> • less than frequency band upper limits • more than frequency band lower limits • divisible by 6.250 kHz (if ch. spacing is 6.25, 12.5 or 25 kHz) • divisible by 10 kHz (if channel spacing is 20 kHz) <p>Default value: 350.000 or 438.000 MHz</p>
Reference Frequency	<p>Nominal frequency to which RX or TX frequencies are referenced to when using SL commands “SL&+=” and “SL&-”. In most cases the setting can be ignored.</p> <p>Default value: 350.000 or 438.000 MHz</p>
Channel Spacing (Width)	<p>6.25, 12.5, 20 or 25 kHz</p> <p>Channel spacing defines the frequency difference between adjacent radio channels. In the context of SATEL-EASy+ modems it also defines the width of the radio channel.</p> <p>Default value: 12.5 kHz</p>
Tx Power	<p>EASy+ supports transmitter output power levels: 10, 20, 50, 100, 200, 500 or 1000 mW. Default value: 1000 mW</p>
Signal threshold	<p>RSSI Signal threshold defines the minimum power level (dBm) of the radio signal to be received. Any transmissions below the threshold level are ignored. Note that the greater the absolute value is the weaker is the signal threshold level (-110 dBm is weaker than -90 dBm). Value range is -80 ... -118 dBm.</p> <p>Default value: -115 dBm</p>
Channel list	<p>Selects whether the list of predefined radio channels is used for the configuration of radio parameters.</p> <p>Default value: Channel list OFF</p>
TX Start Delay	<p>Defines the extra time (0...65000 ms) the radio modem waits before starting to transmit. Data is buffered during the delay.</p> <p>Default value: 0 ms (=no delay)</p>
RX Delay	<p>Defines the extra time (0...255 ms) the radio modem waits before starting to forward data to RD line. Data is buffered during the delay.</p> <p>Default value: 0 ms (=no delay)</p>

Radio Compatibility *)	Defines the radio protocol Options are SATELLINE-3AS, SATELLINE-3AS NMS, SATELLINE-3AS-OA, SATEL-8FSK-1, SATEL-8FSK-2, SATEL-16FSK-1, SATELLINE-2ASxE, PacCrest-4FSK, PacCrest-GMSK TrimTalk450s (P), TrimTalk450s (T), PacCrest-FST, SOUTH Default value: SATELLINE-3AS
Call Sign	Call sign means that the modem transmits its Call sign ID periodically using Morse keying. Call sign is configured using three settings: a) Call sign mode sets Call sign operation ON/OFF. b) Call sign ID defines Morse code to be transmitted, max. sixteen characters, capital letters and numbers are allowed (lower case letters are converted automatically to uppercase letters). If Call sign mode is not used (OFF) you can enter e.g. "CALLSIGN" for the Call sign ID. c) Call sign timer is the interval (1...30 min) between Call sign transmissions. One Call sign transmission may take several seconds to transmit, depending on the Call sign ID. Default value: Call sign mode OFF
RX Address	See the chapter REPEATER MODE AND ADDRESSING Default value: OFF (Rx Address Disabled)
TX Address	See the chapter REPEATER MODE AND ADDRESSING Default value: OFF (Tx Address Disabled)
RX addressing to RS port	See the chapter REPEATER MODE AND ADDRESSING Default value: OFF
TX address auto switch	See the chapter REPEATER MODE AND ADDRESSING
Serial port 1 Status***	Defines Port 1 status Options are: OFF / Diagnostics (NMS) / Data Default value: Data
Serial port 1 Interface***	RS-232 (fixed)
Serial port 1 Data speed***	1200, 2400, 4800, 9600, 19200, 38400, 57600, 115200 bps Default value: 115200 bps
Serial port 1 Data bits***	7 <i>Note**</i>), 8 bits Default value: 8 bits
Serial port 1 Parity bit***	None, Even, Odd Default value: None
Serial port 1 Stop bits***	1 or 2 Default value: 1
Serial port 2 Status***	Defines Port 2 status Options are: OFF / Diagnostics (NMS) / Data Default value: Diagnostics
Serial port 2 Interface***	Available selection is: RS-232/422/485

	Default value: RS-232
Serial port 2 Data speed***	1200, 2400, 4800, 9600, 19200, 38400 57600, 115200 bps Default value: 115200 bps
Serial port 2 Data bits***	Fixed to be 8bits
Serial port 2 Parity bit***	None, Even, Odd Default value: None
Serial port 2 Stop bit***	1 or 2 Default value: 1
CTS handshaking***	Defines how CTS line acts, the choices are: Clear to send and TX buffer state. Default value: Clear to send
CD handshaking***	Defines how CD line acts, the choices are: RSSI-threshold, Data on channel, Always ON and Ext Antenna Control. Default value: RSSI- threshold
RTS handshaking***	Defines how RTS line acts, the choices are: Ignored, Flow Control, Reception Control Default value: Ignored

Pause length***	The radio modem recognizes pauses on the serial line and uses them as criteria for ending the transmission and finding SL commands. The value range is 3....255 bytes. In case the serial port data to be transmitted includes pauses between the characters inside messages, increasing Pause length will help in keeping the message in one part over the radio. In general, the value should be kept as small as possible in order to maximize the performance of the radio system. Default value: 5
Error correction (FEC)	ON/OFF FEC (Forward Error Correction) improves the reliability of data transfer over a noisy radio channel. FEC is recommended in case the link distances are long or if the radio channel is not clean. However, FEC ON decreases the data transfer speed by about 30 % (depending on used modulation level). All radio modems, that are to communicate with each other, must have the same setting for FEC (ON or OFF). Note that FEC setting applies only to the SATELLINE-3AS radio protocol, the other radio compatibility modes have their own FEC bindings (although some previous or special firmware versions differ in the way FEC setting is handled - in case of doubt please contact technical support) Default value: OFF
Error check	ON/OFF

	Default value: OFF
Repeater	Repeater Mode selects whether the radio modem forwards the received messages over the radio or not. Addressing must be also used in the systems that include more than one repeater, in order to prevent the messages bouncing between the repeater stations. Default value: OFF
SL commands	SL command mode ON/OFF When enabled, the modem can be configured/controlled by using the SL commands. Default value: ON
Priority	TX or RX Default value: TX
FullCR16 Check	ON/OFF Default value: OFF

LCD Mode	<p>Normal (factory default)</p> <ul style="list-style-type: none"> - Allows the user to read and change the parameters via push buttons and LCD display <p>Read-only</p> <ul style="list-style-type: none"> - Allows the user to read the parameters from the display but modifying them is possible only via configuration software <p>SURV</p> <ul style="list-style-type: none"> - Selectable parameters via LCD UI: channel, compatibility, Repeater -mode, FEC -mode. NOTE! Channel list always ON. Channel list parameters must be configured properly. See chapter "Channel List" for detailed information <p>SURV Read-only</p> <ul style="list-style-type: none"> - Allows the user to read the SURV parameters from the display but modifying them is possible only via configuration software
Add RSSI to data	If the function is ON, RSSI information is appended to the received data. RSSI info "\02RSSI:-nnn dBm\03" in the end of serial port messages, nnn is three-digit decimal number. Default value: OFF
Region Code	<p>Region code defines the regional settings that firmware uses.</p> <p>US: Starting from the 1st of Jan 2013 FCC regulations state, they will allow transmission on 25 kHz radio channels only if the link rate of the radio is at least 19200 bps.</p> <p>In case Region code is set to US and the active setup violates above mentioned FCC requirement, the radio modem cuts the transmitter power level to zero (0 W) when transmitting. The</p>

	radio modem is ensuring it is operating according to the FCC requirement. Default value: No regional settings defined.
Routing	See the chapter MESSAGE ROUTING Default value: Routing mode OFF
Tests	Set ON/OFF Default value: OFF
Customer Info 1	Any arbitrary text (max. 32 characters) can be saved in the setting for identification purposes etc.
Customer Info 2	Any arbitrary text (max. 32 characters) can be saved in the setting for identification purposes etc.
Customer Info 3	Any arbitrary text (max. 32 characters) can be saved in the setting for identification purposes etc.

IP Address****	Specifies the IP address and mask of the device Default: 192.168.1.1/24
Default Gateway****	Specifies the IP address used to route traffic from the device to external networks. Default: 192.168.1.2
DHCP State****	Selects how the device obtains its IP address: 0 = OFF (manual configuration), 1 = DHCP Client (automatic assignment by network). Default: OFF
IP Mode****	Defines the device's network role: 0 = Disabled, 1 = Server (accepts incoming connections), 2 = Client (initiates connections). Default: Server
Protocol****	Specifies the transport protocol for communication: 1 = TCP 2 = UDP Default: TCP
Destination Port****	The port number used for outgoing data in Client mode. Range: 1-65535. Default: 2006
Destination Address****	The IP address where data is sent in Client mode. Range: 1-65535. Default: 192.168.1.2
Listening Data Port****	The port number for incoming data in Server mode. Range: 0-65535. 0 disables the data server. Default: 2005
Listening Diag Port****	The port number for incoming diagnostic connections in Server mode. Range: 0-65535. 0 disables the diagnostic server. Default: 55555

TCP Timeout (ms) ****	The maximum time (in milliseconds) the device waits for TCP connections before timing out. Range: 0-65535, 0 means no timeout Default: 1500
USB Port Function****	Determines the USB port's role: 1 = Data 2 = Diagnostics (NMS data) Default: Diagnostics
Bluetooth Mode****	Sets the Bluetooth operating mode: 1 = Server (accepts connections), 2 = Client (initiates connections). Default: Client
Friendly Name****	The name displayed to other devices during Bluetooth discovery and pairing. Length 1-30 chars Default: SATEL EASy+
Device Name****	The BLE (Bluetooth Low Energy) device identifier shown to other devices. Length 1-30 chars Default: SATEL EASy+ BLE
Bluetooth Chip State****	Enables or disables the Bluetooth radio: ON = active, OFF = inactive. Default: ON
Visibility Timeout (s) ****	Duration (in seconds) the device remains visible for pairing after activation. Limit: 0-65535. 0 means that it is always visible. Default: 120
Bluetooth Port Function****	Sets the Bluetooth port's role: 1 = Data 2 = Diagnostics (NMS data) Default: Data

Note *) Ask availability from SATEL / check the chapter SATEL-EASy+ technical specifications.

Note **) Supported serial port parameters: 7N2, 7E1, 7E2, 7O1, 7O2

Note ***) SATEL-EASy+

Note ****) SATEL-EASy+ ETH

12 CONFIGURATION

12.1 Radio modem configuration

The configuration of settings can be changed in several ways. User can choose several methods such as:

LCD menu & Push buttons (the models equipped with a display) The basic settings are accessible from LCD and push buttons. Some of the functions, for example the Channel list editing or configuration of Message routing is to be performed using PC software.

SL commands A terminal device can command or configure the radio modem by using special commands. SL commands are applied especially in cases where radio modems are to be integrated seamlessly inside a system behind the integrator's own user interface. See chapter "SL Commands" for details.

SATEL NETCO DEVICE

SATEL NETCO DEVICE is a software for configuring and reprogramming a SATEL device. The configuration parameters can be read and written from/to the locally connected, powered device. The device configuration can be also created/saved/explored from/to a file without device connection.

SATEL Configuration Manager

SATEL Configuration Manager is a software for configuring and reprogramming a SATEL device. The parameters can be read and written from/to the connected, powered device. The program file can be saved into a separate file to be used to other devices. The most common use case for which the SATEL Configuration Manager is optimized for is editing existing parameters in a SATEL radio product using locally connected product over a serial interface. For new networks, SATEL NETCO DEVICE SW tool is recommended.

Please visit SATEL WEB pages for suitable software tools and to find additional information regarding SW tools: <https://www.satel.com/products/software/>

12.2 Radio network configuration

For radio network routing configuration and monitoring SATEL has following free of charge and easy to use software:

SATEL NETCO DESIGN

SATEL NETCO DESIGN is an intuitive and user-friendly software for network design, configuration and management. The software supports configuration of the Routing Setup (Source Routing) and NMS Routing Setup -modes for SATEL-EASy+ product family.

SATEL NETCO NMS

SATEL NETCO NMS is an intuitive and user-friendly network configuration software for network design and management with radio network monitoring option. The software supports configuration of the Routing Setup (Source Routing) and NMS Routing Setup -modes for SATEL-EASy+ product family.

SATELLINE SaTerm

SATELLINE SaTerm is a terminal software to assist in the configuration, testing and reprogramming of the SATEL devices. This software supports the Routing Setup -mode, a graphical tool for easy configuration of the Message Routing feature (Source Routing). Routing Setup refers to Message Routing feature for SATEL-EASy+ family serial radio modems, where messages can be automatically routed over the radio network to correct recipient terminal. For new networks, SATEL NETCO SW tools are recommended.

SATEL NMS PC

SATEL NMS PC is a software for creating and managing NMS Routing networks with radio network monitoring option (SATEL-EASy+). For new networks, SATEL NETCO SW tools are recommended.

Please visit SATEL WEB pages for additional information:

<https://www.satel.com/products/software/>

12.3 SATEL COMMAND

SATEL-EASy+ ETH with Bluetooth can be configured with the SATEL COMMAND mobile app. Bluetooth Port Function must be set to "Data".

13 DISPLAY AND PUSH BUTTONS

SATEL-EASy+ includes a LCD (Liquid Crystal Display) with a backlight. In the *Data Transfer Mode* the display will show the operating settings of the radio modem, for example the radio field strength and the supply voltage. By using the push buttons and the display, it is possible to change most of the settings of the radio modem, without the need for an external terminal. The display backlight illuminates automatically as soon as a button is pressed.

When the SETUP-push button (■) is pressed, a settings menu is opened. It contains several sub-menus that can be selected in order to change the settings. You can always return to the previous higher level of the menu structure by pressing the CANCEL (or BACK) push button (●). Pressing the ▲ or ▼ button changes settings or moves in the menu. Selections are confirmed by pressing the SELECT or SET button. In case of numerical values the digit to be changed is selected by pressing the NEXT button (see following page).

The SATEL-EASy+ includes following “LCD Mode” options for the models that are equipped with LCD UI:

- Normal (factory default)
 - o Allows the user to read and change the parameters via push buttons and LCD display
- Read-only
 - o Allows the user to read the parameters from the display but modifying them is not possible via LCD UI.
- SURV
 - o Selectable parameters via LCD UI: channel, compatibility, Repeater -mode, FEC – mode. NOTE! Channel list forced ON. Channel list parameters must be configured properly. Asterisk (*) next to the power level means that the active power level is set to be lower than the current channel allows.
See chapter “**Channel List**” for detailed information
- SURV Read-only
 - o Allows the user to read the SURV parameters from the display but modifying them is not possible via LCD UI. See chapter “**Channel List**” for detailed information

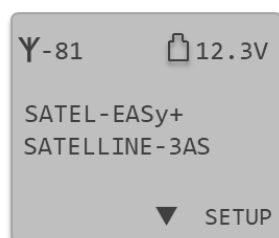

Normal/Read-only “LCD Mode”.

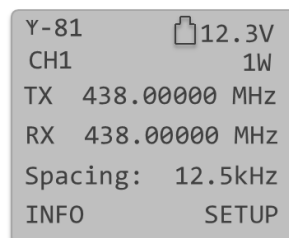

SURV/SURV Read-only “LCD Mode”.

The “LCD Mode” can be configured via SATEL configuration software tools or SL commands. See chapter “Configuration” for additional information.

13.1 LCD menu navigation

Below is a figure for supported menu items and navigation in normal mode for SATEL-EASy+.

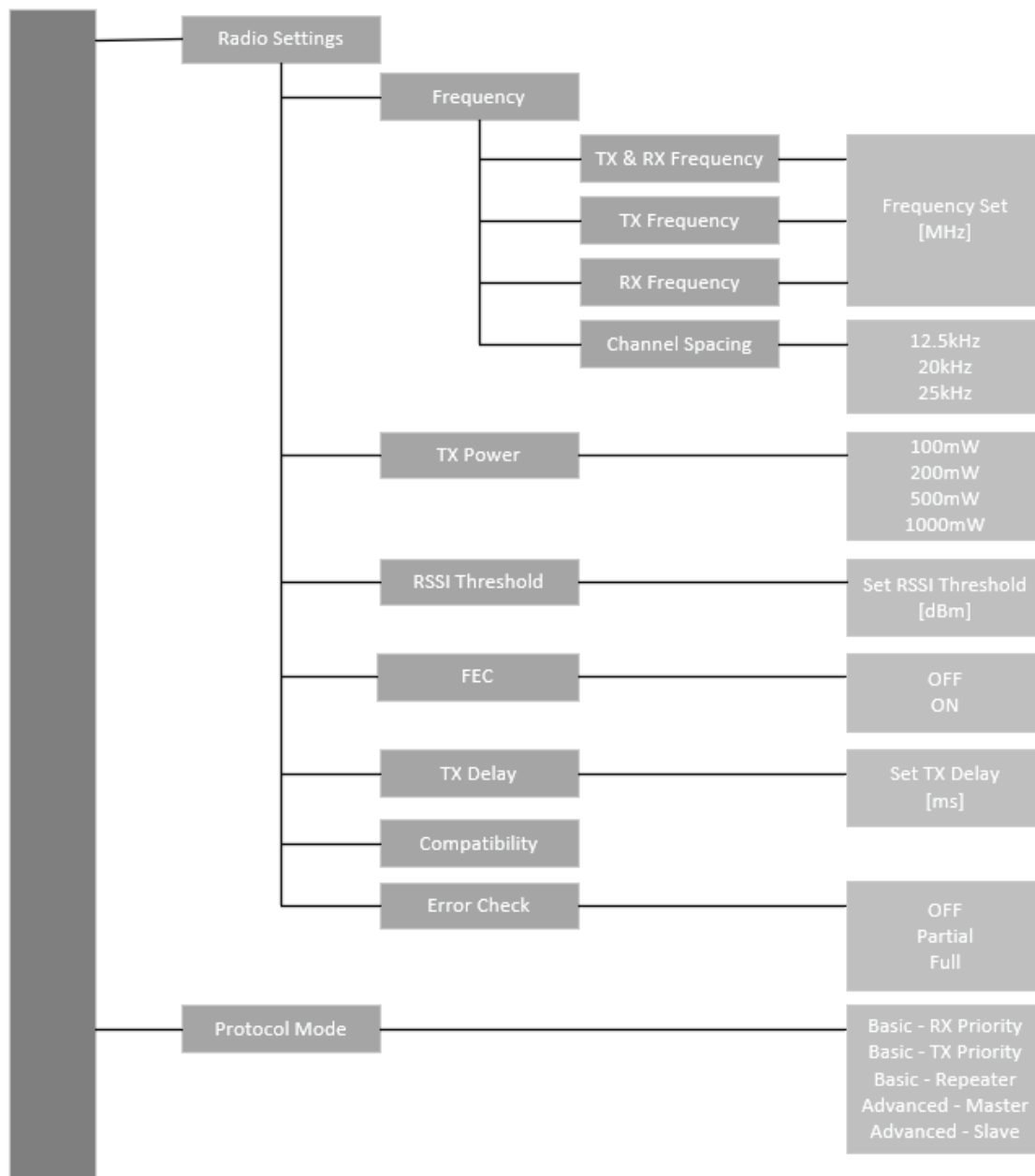

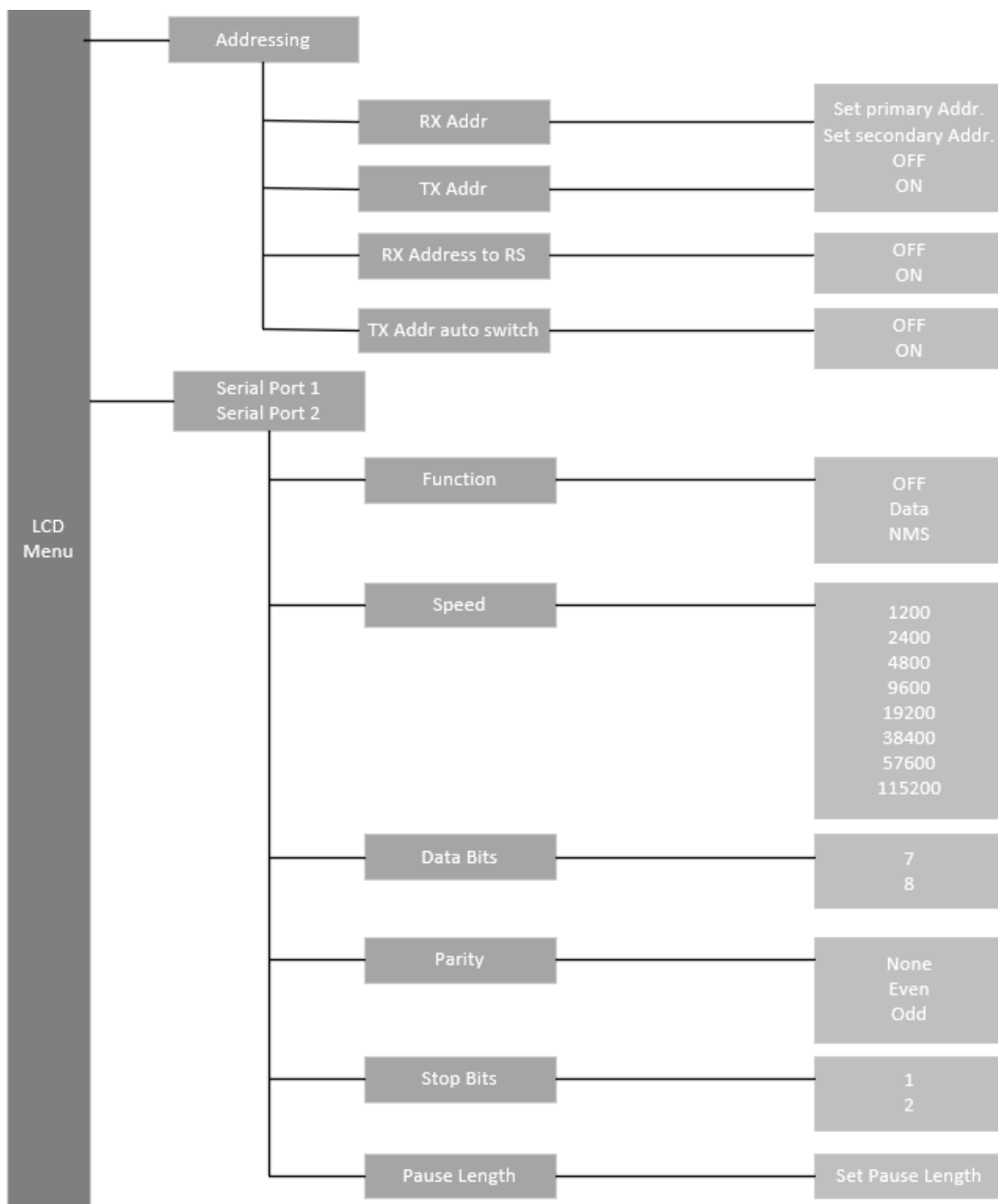

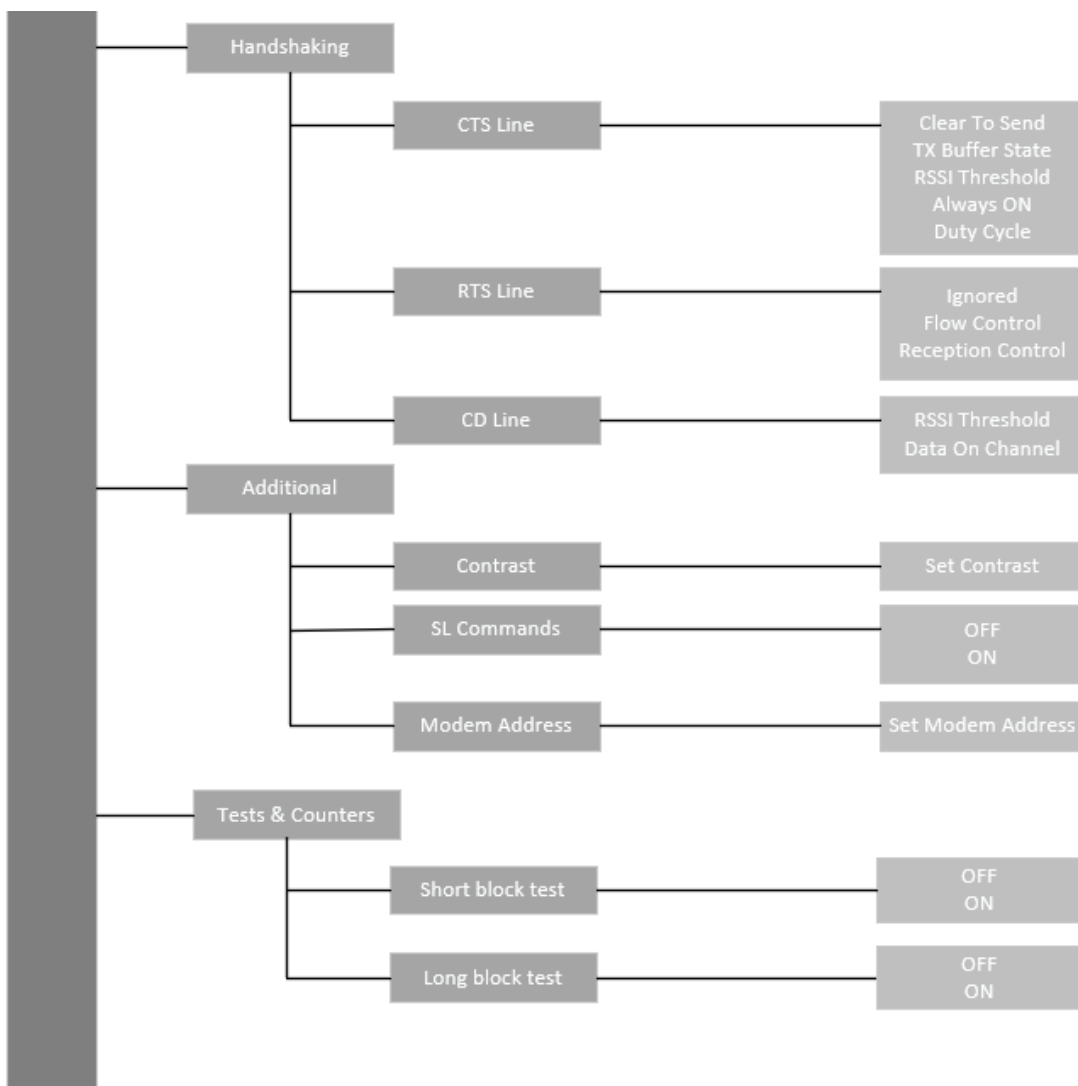



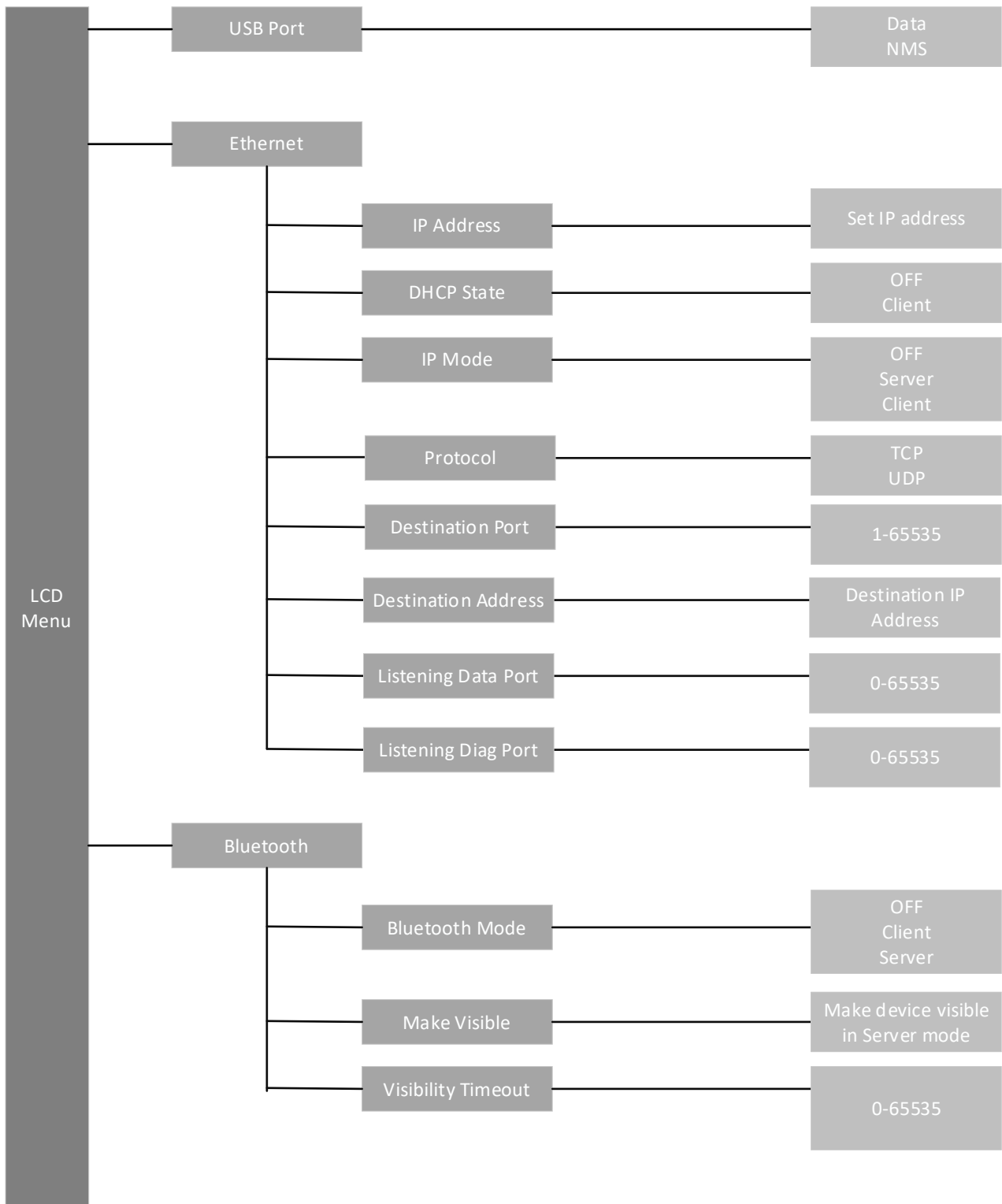

SATEL-EASy+ ETH removes all menus related to the serial port, and adds the following menus:



13.2 Push buttons

	UP	Pressing <i>UP</i> (▲) button the cursor moves upwards. Depending on the sub-menu, the button also scrolls the digits of numerical values when changing some settings.
	DOWN	Pressing <i>DOWN</i> (▼) button the cursor moves downwards. Depending on the sub-menu, the button also scrolls the digits of numerical values when changing some settings.
	SELECT/SET/CHANGE /NEXT/YES	Pressing <i>SELECT/SET/CHANGE/NEXT/YES</i> (■) button either confirms a selection, sets or changes a value, moves to the next digit or enters a sub-menu depending on the context.
	EXIT/CANCEL/BACK/ NO	Pressing <i>EXIT/CANCEL/BACK/NO</i> button escapes back to the previous higher level in the menu hierarchy or cancels the modification of a setting depending on the particular submenu.

14 SL COMMANDS

14.1 Changing parameters using the SL COMMANDS

The controlling terminal device can change the configuration settings of a radio modem. This is accomplished with the help of SL commands, which can be used during data transfer. SL commands can be used to change e.g. the frequency or addresses. It is also possible to interrogate a radio modem in order to gain information concerning current settings that are in use. The terminal device is either a PC or a programmable logic (PLC) together with suitable (terminal) program. SL commands must be enabled before they can be used. SL commands work through the serial port, USB, Ethernet and Bluetooth.

An SL command is a one continuous string of characters, which is separated from other data by pauses that are equal or greater than time defined by Pause length parameter in the set-up. No extra characters are allowed at the end of an SL command. Serial interface settings are the same as in data transfer and pin 12 of the serial connector **MUST NOT** be connected to ground (GND). SL command is properly recognised also in the case when the command string is terminated in <CR> (=ASCII character no. 13, Carriage Return, 0x0d) or <CR><LF> (<LF> = ASCII char. no. 10, Line Feed, 0x0a). Pause according to set Pause Length -parameter is required also in this case. If multiple SL commands are sent to the radio modem the next command can be given after receiving the response ("Ok" or "Error") of the proceeding command. In addition, it is recommended to implement a timeout to the terminal software for recovering the case when no response is received from the radio modem.

When the power of a radio modem is switched off the configuration settings of a radio modem always return to configured (and saved) values, thus resetting any settings changed using SL commands during power on. It is however possible to save settings changed by using SL commands and to make them the new configuration settings.

SL Command -modes:

- ON (factory default)
 - SL commands are processed by the local radio
- OFF
 - SL commands can be operated only when "Command Mode" is set
- ON with CR/LF
 - SL commands are processed by the local radio, response include CR/LF
- OFF with CR/LF
 - SL commands can be operated only when "Command Mode" is set, response include CR/LF

The radio modem will acknowledge all commands by returning an "**OK**" (command carried out or accepted) or the requested value, or an "**ERROR**" (command not carried out or interpreted as erroneous) message. SL command response time depends on the used command. Typical

response time is ~100ms and upwards. Recommended safe timeout for SL command response is 500ms.

To get information of the latest and/or special SL commands please contact SATEL or local SATEL distributor: <https://www.satel.com/where-to-buy/>.

14.2 Command Mode

Command mode purpose is separate device normal condition from configure condition. When command mode is active, device is looking for known commands from serial interface data. Command mode enables forcibly the SL command mode and disables the radio interface functions (Tx/Rx).

14.2.1 Entering to command mode - +++

Entering to command mode is performed when device gets three (3) '+' characters in a row. Between characters needs to be a delay of pause length. In this way device can decide that it is required to enter command mode after three correct characters. First two (2) '+' -characters is transmitted by radio, because device cannot know at this point whether the last character is correct. After successfully given command mode entering syntax, device responds "OK<CR><LF>". Below is a figure to entering command mode.

+ <pause length> **+** <pause length> **+**

Delay between characters depends on what is the current serial baud rate. See specifications of three (3) character delays below in "Table 1. Delay in different baud rates".

14.2.2 Return to data mode - ---

When command mode is active, it is possible to return in normal data mode by giving three (3) '-' -character in a row. Sequence is same as entering to command mode, so there is also needed the delay of pause length between sending the characters. After successfully given exit command mode syntax, device responds "OK<CR><LF>". Below is a description how to exit command mode.

- <pause length> **-** <pause length> **-**

Delay between characters depends on what is the current serial baud rate and pause length setting. See example of delays below in "Table 1. Delays in different baud rates", when e.g., pause length setting is set to three.

Baudrate	3 Character delay [ms]
2400 bps	12.5
4800 bps	6.25

9600 bps	3.13
19200 bps	1.57
38400 bps	0.79
57600 bps	0.52
115200 bps	0.26

Table 1. Delays in different baud rates

15 CHANNEL LIST

A list of predefined radio channels can be stored in the memory in order to change the radio settings simply by switching between the channels. Each channel carries the following info:

- Channel number (unique number for each channel, any number -32767...32767)
- Transmitter/Receiver frequency
- Channel width (12.5, 20 or 25 kHz)
- Transmitter power level (optional)

Additionally, the default channel that the radio modem uses after a reset is defined.

When TX frequency of the active channel is set to 0, the radio modem operates as receive-only device (in case the value of Rx frequency is valid).

Channel lists can be created and utilized by using either SATEL NETCO DEVICE or SATEL Configuration Manager software tools or SL commands. Software tools provide a channel list editor (snapshots below) for creating and saving a channel list in the radio modem, or in a file for later usage.

The screenshot displays the configuration interface for the SATEL NETCO DEVICE CE, specifically the 'CHANNEL LIST' section. The interface is divided into several tabs: GENERAL, RADIO, CHANNEL LIST (selected), SERIAL INTERFACE, NETWORK PROTOCOL, SOURCE ROUTING, and DIAGNOSTIC. The 'CHANNEL LIST SETTINGS' section includes fields for 'File import', 'File export', 'Use Channel List' (a toggle switch currently set to OFF), 'Manual Scan Channel Count' (set to 2), and 'Manual Scan Default Channel' (set to 1). Below this is a table titled 'CHANNEL LIST (2)' with two entries:

Channel List [0]	N:1 FT:433000000 FR:433000000 W:25000 P:0
	Buttons: Set Default, Add Before, Add After, Delete, Close
Channel List [1]	N:2 FT:433050000 FR:433050000 W:25000 P:500

To the right of the channel list is a 'SETTING ASSIST' panel for the selected channel. It provides detailed information:

- Channel List**: Channel list item format: N:xxxx FT:xxxxxxxx FR:xxxxxxxx W:xxxx P:xxx
- Value range**: User Channel: -32767 .. 32767; TX Frequency: 403000000 .. 473000000; RX Frequency: 403000000 .. 473000000; Channel Width: 12500,20000,25000; TX Power: 0,10,20,50,100,200,500,1000
- Data id**: 1.1600-1.1799
- Array index**: 0
- Default value**: N:0 FT:0 FR:0 W:12500 P:0
- Orig. value**: N:1 FT:433000000 FR:433000000 W:25000 P:0
- Value**: N:1 FT:433000000 FR:433000000 W:25000 P:0
- Units**: -

At the bottom of the interface, it shows 'ce 2.18.0 advanced serial' and the SATEL logo.

SATEL NETCO DEVICE.

The screenshot shows a window titled "Channel Selector" with a sub-header "Default Channel Set". Below the header is a toolbar with buttons: Clear, Load, Save, Add, Edit, Up, Down, Set default, Delete, and Close. The main area contains a table with the following data:

Index	User Channel	TX Frequency	RX Frequency	Channel Width	Tx Power
0	0	430000000	430000000	12500	1000
1	1	431000000	431000000	12500	1000
2	2	432000000	432000000	12500	1000

SATEL Configuration Manager.

Entering the Channel List -feature parameters require elevated access level to software tools.

See SW compatibility table for details:

<https://www.satel.com/products/software/>

SL commands provide an interface for a host device to command the radio modem directly. An example of the procedure for creating or replacing a channel list:

1. Clear existing channel list (SL\$C=0)
2. Set channel info for each of the channels to be created starting from index 0 (SL\$L=)
3. Set number of channels in channel list (SL\$C=)
4. Set the default channel (SL\$D=)
5. Verify the new configuration:
 - Get number of channels in channel list (SL\$C?)
 - Get channel info for each of the channels (SL\$L?)
 - Get the default channel (SL\$C?)
7. Enable Channel list (SL\$M=1) in order to activate the Channel list
8. Save the settings (SL**>)

16 REPEATER MODE AND ADDRESSING

Repeaters and addressing may be used to extend the coverage area of a radio modem network, and to direct messages to selected radio modems in the network. In large systems, with several repeaters and formed repeater chains, it is often practical to use routing instead of plain addresses.

16.1 Repeater

In circumstances where it is necessary to extend the coverage area of a radio modem network, modem can be used as repeater stations. The Repeater Function is switched ON by user settings.

The maximum size of a repeated data packet is 2kB (two kilobytes). In the repeater mode the radio modem will function as a totally independent unit, which means that only a power supply and a suitable antenna are needed. Other devices are not necessary.

A radio modem acting as a repeater can also be used to receive and transmit data. In repeater mode the radio modem will transmit the received data to the serial interface in a normal fashion. The difference being that the received data will be buffered into the buffer memory. After reception the radio modem will re-transmit the buffered data using the same radio channel as in reception. Data received through the serial interface a radio modem in repeater mode will transmit normally.

The same network may include several repeaters, which operate under the same base station. Repeaters may also be chained; in which case a message is transmitted through several repeaters. In systems with more than one serially or parallel chained repeaters, addressing or routing protocol must be used to prevent a message ending up in a loop formed by repeaters, and to ensure that the message finally reaches only the intended radio modem.

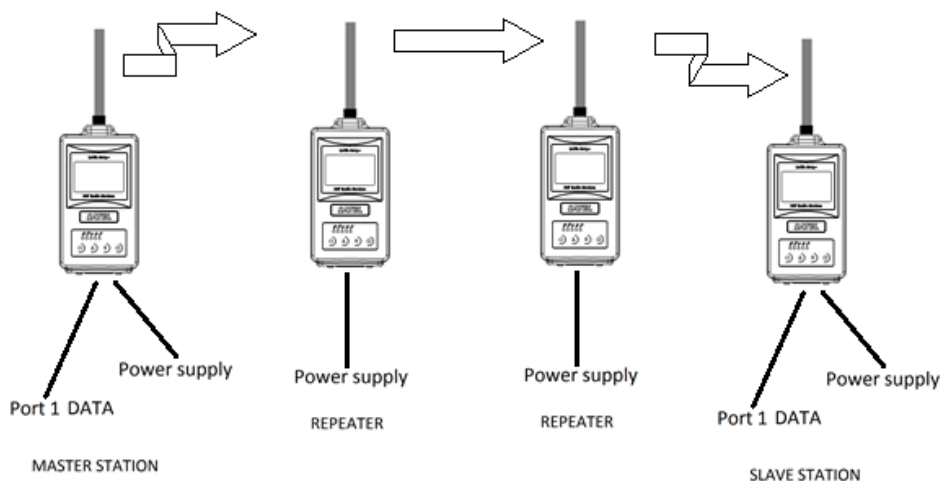

16.2 Addressing

Addresses can be used to route a data message to the desired destination or to separate two parallel networks from each other. In networks with repeaters it is usually necessary to use addresses to prevent data messages from ending up in loops formed by repeaters. In case of setting the “Message Routing” function in use, Tx/Rx addresses are ignored by the modem.

This feature is designed for SATELLINE-3AS, SATEL-8FSK-1, SATEL-8FSK-2 and SATEL-16FSK-1 – radio compatibility modes.

Modem allows the use of individual addresses both for reception and transmission. Addresses can be switched on separately, or simultaneously, in both data transfer directions.

The radio modem contains two transmission and two reception addresses, which are known as the primary address and secondary address. The primary address is used whenever data from the serial interface is transmitted. At the receiving end, the radio modem will receive using either of the two receive addresses.

Secondary transmit address is only used in repeater applications.

Radio modems configured to function as repeaters, will repeat data messages using either the primary or secondary address, depending upon which address was used during the reception of the data message.

If only one address pair is needed in a network, both addresses must be set the same (TX1 = TX2 and RX1 = RX2).

It is also possible to transfer the received address onto the serial interface.

The address is composed of two characters totalling 16 bits, resulting in over 65,000 different address combinations. The address is attached to the beginning of each data packet sent by the radio modem. When a radio modem receives a data packet whilst using addressing mode, the radio modem will check the first two characters of each received data packet to ensure that the packet in question was intended for the correct radio modem.

ADD H	ADD L	DATA
-------	-------	------

Address may be selected between 0000h...FFFFh (h = hexadecimal, corresponding decimal numbers are 0-65535).

Example: address 1234h (4660 in decimal format), where 12h is ADD H and 34h is ADD L.

Example: address ABFFh (44031 in decimal format), where ABh is ADD H and FFh is ADD L.

Transmission:



Transmission address has been set OFF. Radio modem will transmit the data packet as such.

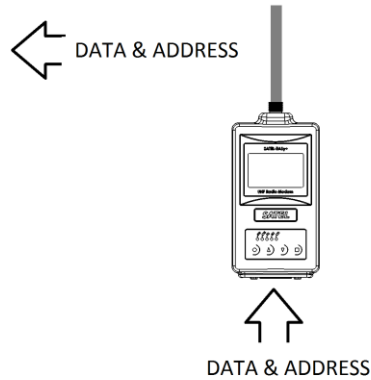

Transmission addressing has been set ON. The radio modem will add the primary TX address to the beginning of the data packet.

Reception:

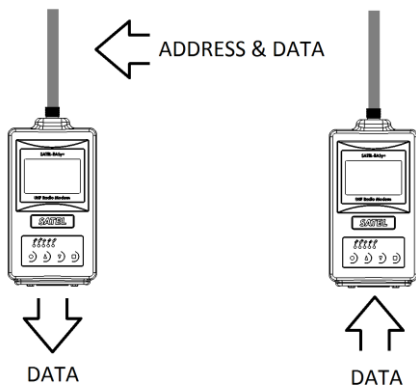

Reception addressing has been set ON and either the primary or secondary RX address of the radio modem is identical to the address of the received data packet.

The radio modem will remove the address and send the actual data to the RS-232 interface.

However, if the "RX Address to RD-line" setting is on, the radio modem does not remove the address.

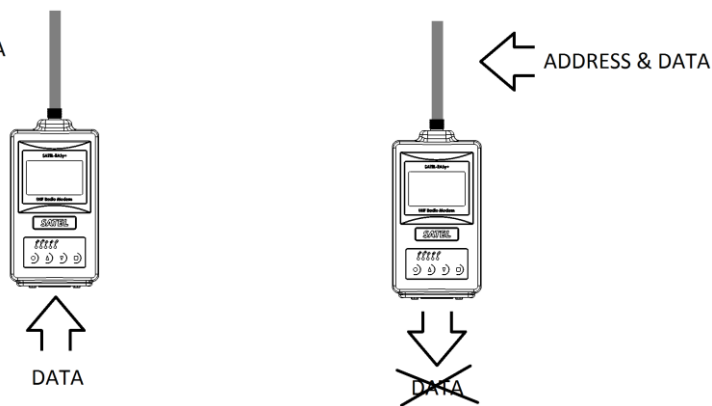

Reception addressing has been set ON, but both the primary and secondary RX addresses of the radio modem are different from the address of the received data packet.

Data does not appear on the RS-232 interface.



Reception addressing has been set OFF.

The radio modem will transfer all received data to the RS-232 - interface.

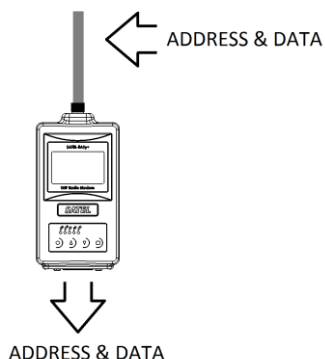

Reception addressing has been set OFF.

The radio modem will consider the characters of the address as a part of the data and will send all the characters to the RS-232 interface.



Reception addressing has been set ON but there is no address in the data packet.

Data will appear on the RS-232 interface ONLY if the first 2 bytes of the data match either of its own RX address. The radio modem will remove those 2 characters of data.

16.2.1 Connection between two points

When forming a connection between two points it is recommended that both the reception and transmission addresses are identical in both radio modems. This is the easiest way to control addresses and the risk caused by interference from other systems operating in the same area is minimal.

Example: by setting all addresses of both radio modems to a value '1234', they will accept only those messages which contain this address, and they will use this same value when transmitting data.

If the channel is reserved for use only by the single network, or if the terminal devices are responsible for addressing, it is not necessary to use addressing in the radio modems.

16.2.2 System of one base station and several substations

In systems with several substations, the base station must know to which substation each message is intended, and from which substation each received message originates. Usually terminal devices handle addressing completely, but it is also possible to use the addressing functionality of the radio modems.

For example, if the substation terminal devices cannot check and form addresses by themselves, addressing may be achieved with the help of the addresses of the radio modems attached to these terminal devices. The base station may, in such a case, define the destination of a message by adding the address of the corresponding radio modem into the beginning of the data packet. The substation radio modem(s) will check the address, and the corresponding radio modem will identify and remove the address characters. In a similar way, the substation will add when transmitting to the base station its address characters into the beginning of the data packet, thus defining the origin of the sent data packet. In the base station radio modem, addresses have been switched OFF, so that they are transmitted as is to the base station terminal device for further processing.

16.3 Using repeaters and addresses in the same system

In systems with several repeaters, a substation and a base-station, addresses must be used in radio modems. It is possible to realise also a system with only one repeater without addressing. In such a case, the base station will however hear the message both from the substation and from the repeater, in other words the message is duplicated as it moves along the route.

There are at least two ways of realising such a system depending on the capabilities of the terminal devices in question and on the number of repeaters to be used and on their relative positions to each other.

16.3.1 System with several repeaters

In systems with several serial or parallel-chained repeaters, addressing must be used to prevent messages from ending up in loops otherwise formed by repeaters, and to ensure that only the desired (addressed) radio modem receives the data intended for it.

All radio modems in the network must be set to a state, in which the RX-addressing is switched ON and TX-addressing is switched OFF. Base-station and all substations add an address string in the beginning of the data to be transmitted. In the relaying of the message addressing is used in the following way:

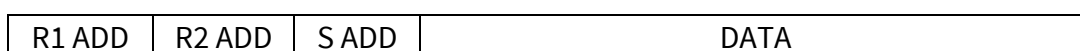

- The above is the data received from the base station terminal device, containing repeater addresses (R1 ADD, R2 ADD) and the substation address (S ADD). Two characters define each address.

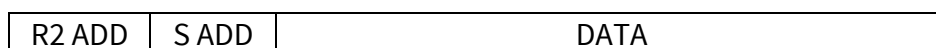

- The above is the same message after being relayed from repeater 1 to repeater 2.

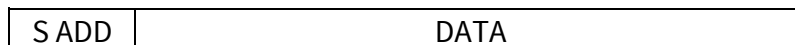

- The above is the same message after being relayed from the last repeater in the chain (repeater 2) to the substation.



- The above is the same message being relayed via the serial interface of the substation radio modem to the terminal device.

In a situation where the substation transmits data towards the base-station the address is formed in a similar way, but the order of the addresses is reversed:

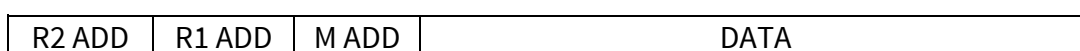

-In the above, R2 ADD is address of repeater 2, R1 ADD is address of repeater 1 and M ADD is the address of the base-station.

16.3.2 Repeater chain using address pairs

In a situation where the terminal devices and substations cannot form address fields, but are able to recognise messages addressed to them, alternating address pairs may be used. Transmit address (TX) and receive address (RX) alternate in the order shown in the table below.

Address type	Base-station address	Repeater 1 and the addresses of the substations of the base-station	Repeater 1 substations addresses
TX-address	Address 1	Address 2	Address 1
RX-address	Address 2	Address 1	Address 2

In a network where alternating addresses are utilised, the exact route that is used to relay a message to a certain radio modem is fixed at the time of installation and configuring the system. The order of the addresses must be the same as the order of the route that is used to relay the message to the radio modem. It should be noted however, that in networks where alternating addresses are used the base-station and substations will hear their own messages repeated.

17 MESSAGE ROUTING

17.1 Introduction to Message Routing

Message Routing is an exciting feature in SATEL-EASy+. This feature allows messages from terminal devices to be automatically routed over the radio modem network to a specified recipient terminal.

In brief, the *Message Routing* works as follows:

- First, a radio modem reads any message coming from the terminal(s) attached to it.
- The radio modem detects the terminal address of the recipient, by seeking a pre-set position inside the message for the address.
- The radio modem checks its internal route table to see, if there is route information corresponding the address it has just found.
- The radio modem transmits a radio frame, which includes
 - network ID (see separate chapter)
 - route information
 - original user message encapsulated
 - redundant information such as checksums for error checking etc.
- The radio modems along the route relay the frame over the network to the radio modem at the destination.
- The radio modem at the destination first checks the validity of the received radio frame, then extracts the original user message, and finally outputs it the terminal device attached to it.

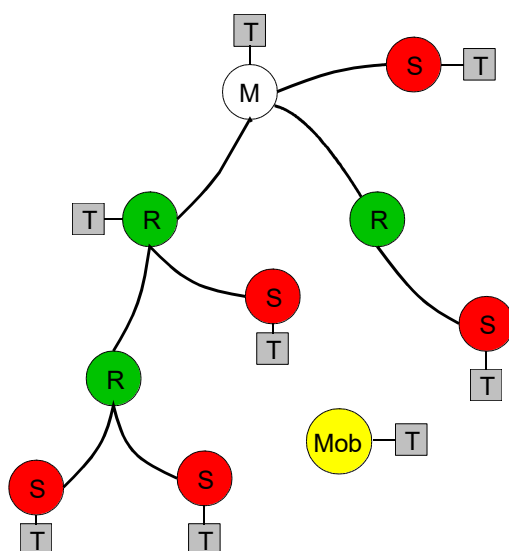

The figure left illustrates a possible structure of a radio modem network.

M = Master station (Central station)

R = Repeater station

S = Slave station

T = Terminal device

Mob = Mobile terminal

Terminals are usually PLC devices that send and receive messages according to a specific user protocol.

Note: The term *repeater* used in the context of the *Message Routing* should not be mixed with the *Repeater Mode*, which is a feature independent from the *Message Routing*.

17.11 Features of Message Routing

The *Message Routing* (Source Routing) feature of the SATEL-EASy+ is designed to be a fast and transparent to fit real time systems. The features include:

- Transparent to user protocols.
- Easy construction of a network containing several repeaters.
- Any radio modem may operate as a repeater, i.e. dedicated repeaters are not usually needed thus cutting down on costs.
- Large areas of coverage may be implemented by using only one radio channel.
- The use of mobile substations is also possible to some extent.
- The system will be fully deterministic i.e. the transmission delays are predictable. Because of that, the principle of *Message Routing* is connectionless.
- Added redundancy as a failing radio modem can be, in certain cases, bypassed with another radio modem positioned in the same coverage area (repeater stations over-hop functionality for dynamic network changes).
- *Message Routing* is intended mainly for the protocols based on polling scheme and a single master station.
- *Message Routing* offers offline monitoring for the radio network RF link health (RSSI).
- *Message Routing* is available in SATELLINE-3AS, SATEL-8FSK-1, SATEL-8FSK-2 and SATEL-16FSK-1 –radio compatibility modes. In case “SATELLINE-3AS” compatibility mode is used, *Message Routing* is compatible also with the widely used SATELLINE-3AS and SATELLINE-EASy radio modem families.

17.12 Limitations of Message Routing

- It is assumed that the position of the address field in the user messages is fixed. Modbus RTU is supported with SATEL-EASy+ with routing *Offset 0* and *Length 1*. However some special protocols are supported:
 - IEC 60870-5-101 is a protocol commonly used in control applications of power lines.
 - RP570/571 protocols
- The message cannot end to the address; there must be at least one character after the address.
- It is assumed that there is only one message at a time inside the network simultaneous messages could cause collisions.
- Up to 100 remotes, max. 16 hops.
- Operation of the Tx / Rx addresses is automatically blocked in the case of switching the “Message Routing” function on.

17.13 Configuration of the Message Routing

The design of any radio modem system requires very precise planning. Once the choices between devices, their location, installation, maintenance etc. are clear, the *Message Routing* for the system can be implemented.

SATEL NETCO DESIGN and SATELLINE SaTerm are a PC SW tools that allows the user to design their required network simply and quickly using a graphical interface to literally draw the network plan on the screen.

- Firstly, a picture of the network is created to show all the radio modems and the intended route that the data is to take.
- Secondly, the required settings are defined in the SW view.
- Finally, the setup of each actual radio modem can be uploaded by connecting the actual radio modems one by one to the COM port to synchronize the radio parameters from SW tool to each radio separately.

Please check the user manuals of *SATEL NETCO DESIGN* and/or *SATELLINE SaTerm* for more details: <https://www.satel.com/support-and-services/downloads/>

See SW compatibility table for compatibility details:

<https://www.satel.com/products/software/>

Additional information available from local SATEL distributors and SATEL technical support.

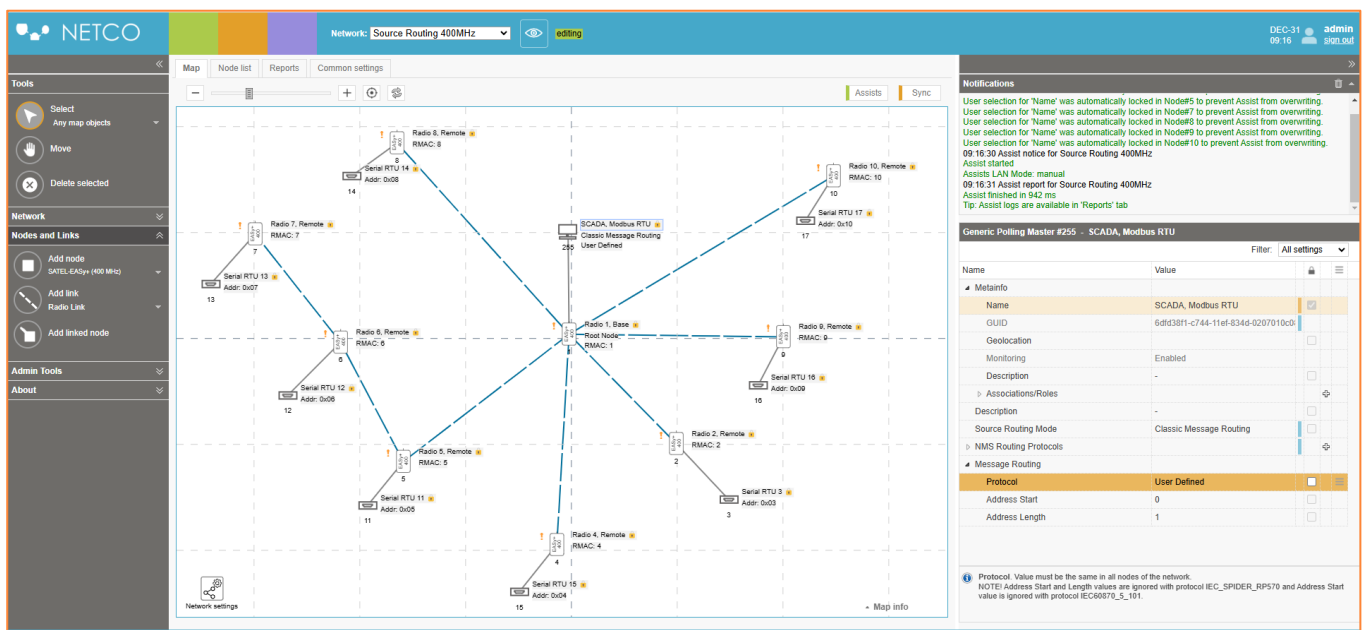

SATEL NETCO DESIGN SW tool, map view.

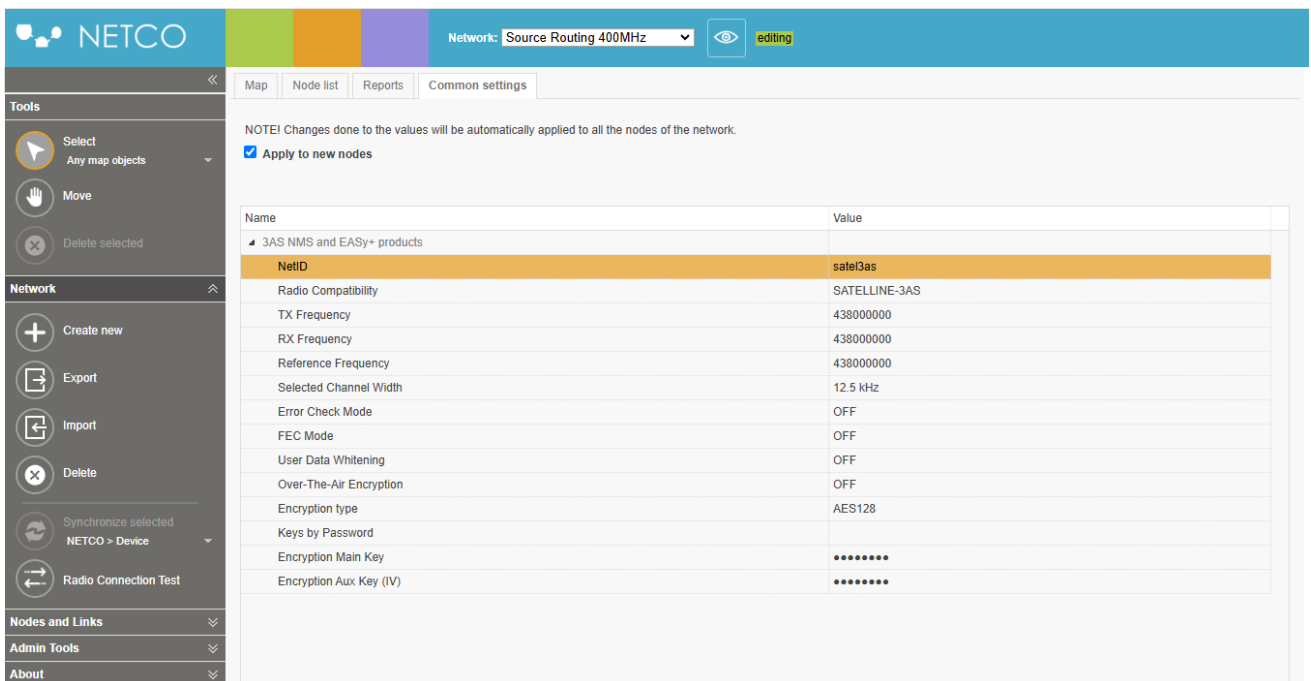

SATEL NETCO DESIGN SW tool, “Common settings” tab for radio critical parameters.

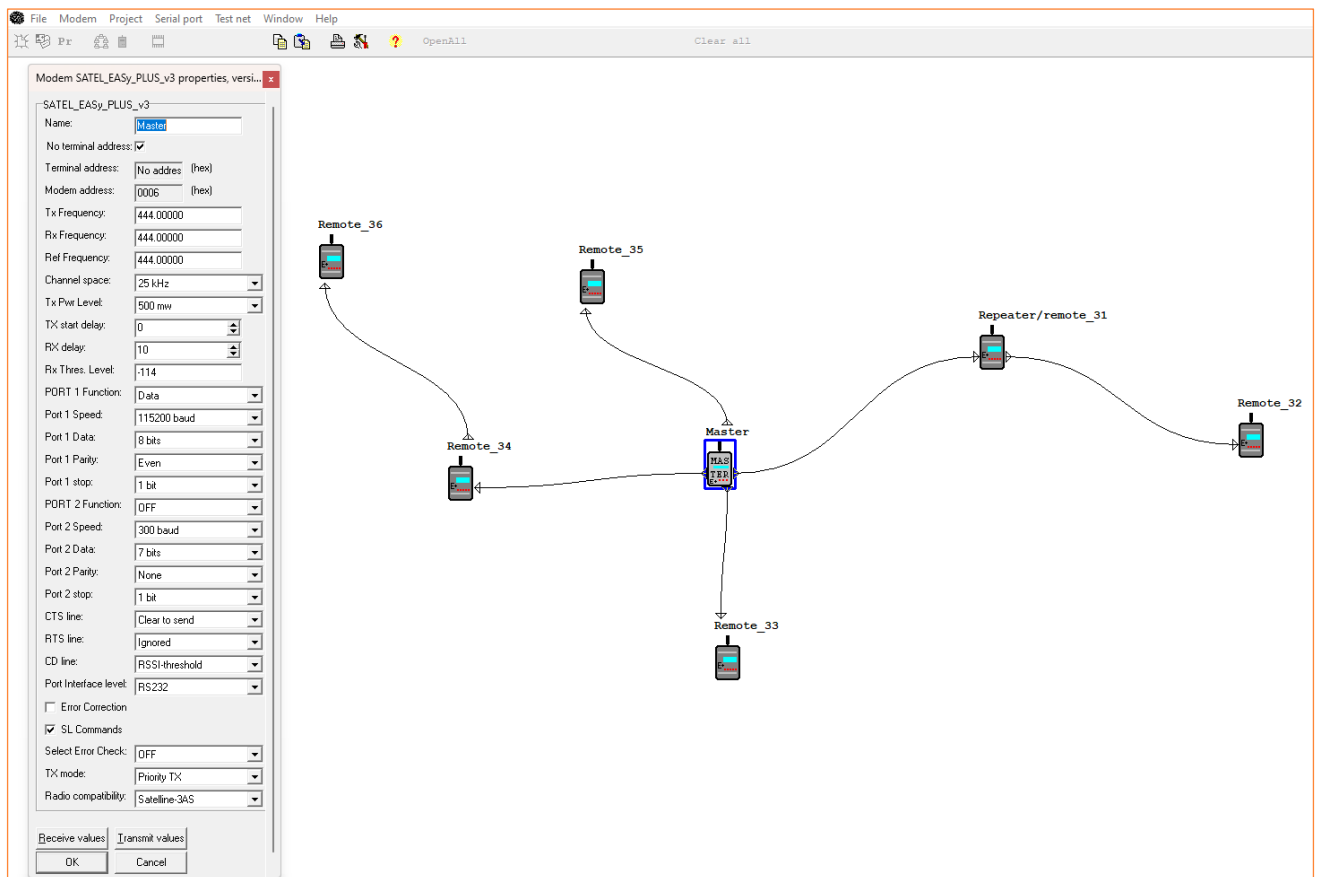

SATELLINE SaTerm SW tool, map view.

17.14 Configuration of the protocol in Message Routing

A radio modem will detect the presence of an address used by inspecting the protocol from the message received via the serial interface. On the basis of this user address, all necessary information needed to relay the message to destination is fetched from an internal routing table inside a radio modem. The user protocol is not interpreted; instead, the user address is searched according to its location in the message. The beginning of the packet is located by a preceding pause in the byte stream. Message Routing can therefore be applied to most protocols with fixed address field position.

The position and length of the address is defined by two settings: *Offset* and *Length*.

- Offset defines the number of bytes (0...15) preceding the address.
- Length is the length of the address in the user protocol expressed in bytes (1...4).

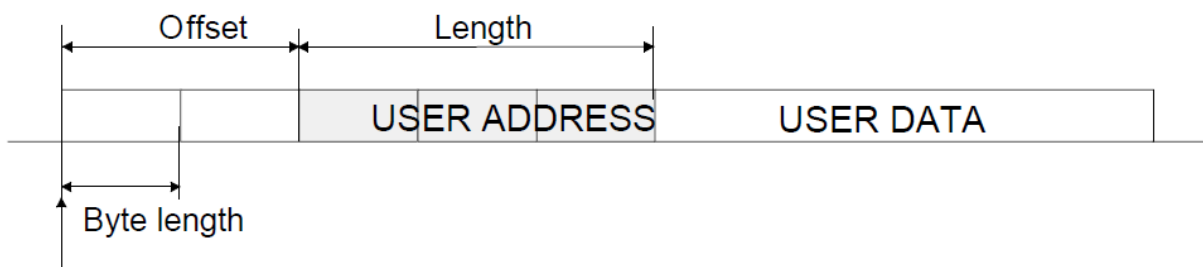

Start of data packet, Offset=2, Length=3

A transmitting radio modem adds a routing header and a tail to the user message. Consequently, a radio modem that receives the message removes the header and tail - so the Message Routing scheme is transparent to the user protocol.

Modbus TCP is supported with SATEL-EASy+ ETH with routing *Offset 6* and *Length 1*. Pre-configured network design templates available in SATEL NETCO DESIGN SW tool. Additional information available from local SATEL distributors and SATEL technical support.

17.2 Detailed description of Source Routing

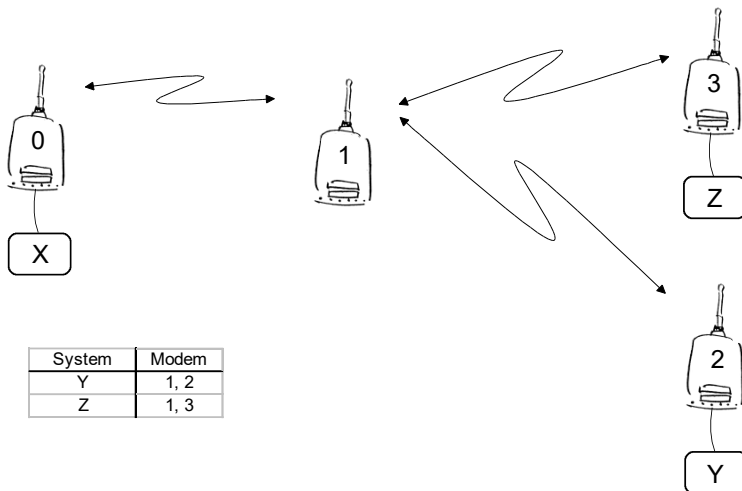

The above figure represents a network containing four (4) radio modems. Each radio modem is given a unique address (0...3). A terminal device has been attached to the three of the four radio modems and they communicate with each other using terminal addresses X, Y and Z, respectively. Radio modem 0 and terminal device X together constitute the base station of the network and all routing information of the network has been programmed into this base station.

When the terminal device X transmits a packet to (e.g.) terminal Y, radio modem 0 will detect the address Y from the data received through the serial port. From the routing table a route 1,2 can be found to which the radio modem also adds its own address to define the route for return data. Radio modem 1 repeats the packet and radio modem 2 removes the address information from the received data packet thereby transferring only the original data to the serial interface. The address information received together with the packet is reversed (2, 1, 0) and saved to be use in the transmission of subsequent reply packets.

17.2.1 Over-hop function in Source Routing

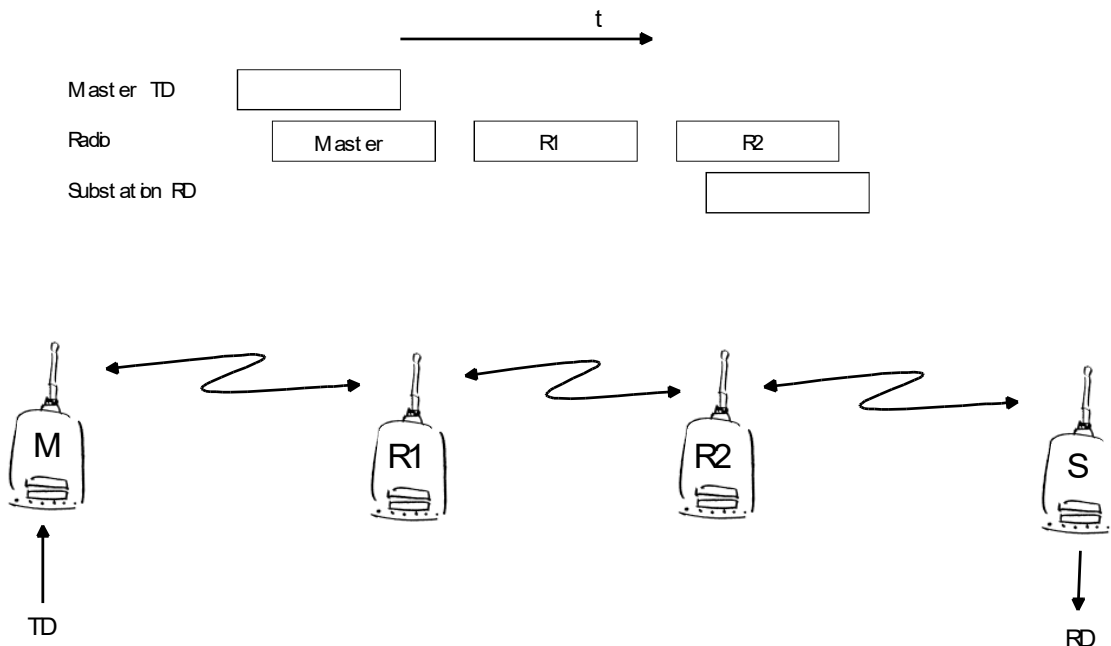

When using repeaters, the same packet is sent via a (radio) channel several times. A radio modem situated in the repeater chain will often hear other radio modems in addition to the immediate neighbouring radio modems. With *Source Mode Routing* the complete address information is sent together with the packets enabling the use of these secondary routes. Usually repeaters have better antennas (and/or antennas placed higher) than normal substations, which means that the distance between two repeaters can be much longer than the distance between a repeater and a substation.

Connections to other than the neighbouring stations of the repeater are not necessarily reliable under all possible (radio) conditions, but they can often be used to keep the network up and running at least partially should a repeater somewhere in the middle of the chain fail. In addition to this, the likelihood of a transmission error decreases if it is possible to listen to more than one transmission since; in this case, it is more likely that at least one of them will be received error-free. It is also possible, that the radio connection is asymmetrical due to the greater output power of a repeater or due to local interference, in which case, data can in fact travel in opposite directions using different routes.

When a repeater receives a message that contains its address but not as the first address in the address field, the packet is stored in a buffer. If the relayed message from the repeater, and the modem having sent the message originally, is not received (due for example, because of radio modem failure or if it has an erroneous checksum), the packet already buffered into the memory is re-sent without any change to the timing (no additional delays are introduced). Because of this, relatively short hop distances can be used, without the likelihood of errors being increasing due to the added number of repeats. A possible error in one of the repeaters does not necessarily cause a total breakdown of traffic.

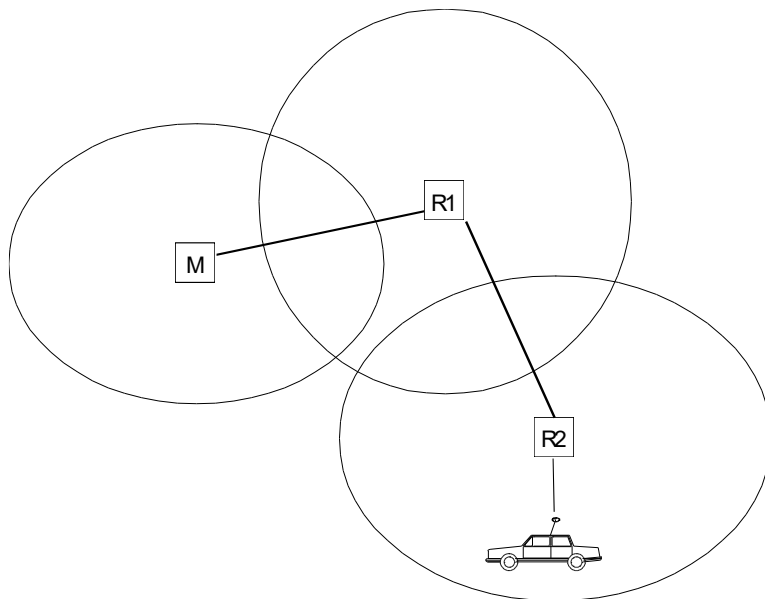

The over-hop function allows for the use of mobile substations. In the example above, a mobile substation is first located in the coverage area of repeater R2. The route is defined as M, R1, R2 and vehicle. When the vehicle moves to the coverage area of repeater R1, the radio modem picks the packet already from the transmission of R1. This is then transferred to the serial port using an additional delay, so that the timing does not differ from the first situation where the radio modem of the vehicle was in the coverage area of repeater R2. In this way a collision of the reply transmission and the transmission by repeater R2 is prevented. When the mobile station is transmitting, it is enough that at least one radio modem defined to be a part of the route receives the transmission.

17.2.2 Network ID

The Network ID is a string of up to eight characters, which is used to prevent the reception of the messages coming from an external system. The radio modems operating in the same system using *Message Routing* must have the same Network ID. Only the messages that have a matching Network ID are received.

18 NMS Network Management System

The purpose of the NMS (Network Monitoring System) is to provide tools for management of a radio network built on SATEL-EASy+ radio modems. NMS allows user to manage, monitor, diagnose and configure SATEL-EASy+ modem network remotely without disturbing user's data flow.

This chapter includes a very short description of SATEL NMS for SATEL-EASy+ radio modem family. More information is provided by the SATEL NETCO NMS and SATEL NMS PC user manuals and application notes.

See SW compatibility table for compatibility details:

<https://www.satel.com/products/software/>

18.1 System components

SATEL NMS consists of:

- SATEL NETCO NMS (or SATEL NMS PC) program. The program provides the user interface showing the status of the network:
 - Graphical network overview
 - Sort able lists of all modems and radio links
 - Link quality tests and monitoring
 - Alarms generated on link failure, operating voltage drop etc.
 - Remote administration of modem parameters
 - Log files
- The diagnostic functions in the SATEL-EASy+ radio modem software. The set of features depends on the hardware and software version of the radio modem.
 - One of the modems operates as the *Master modem* of the system (*Network Mode* parameter of the radio modem set to *Advanced - Master*).
 - The other modems are the *substations* of the network (*Network Mode* parameter of the substation radio modems set to *Advanced - Slave*).

18.2 NMS - Installation

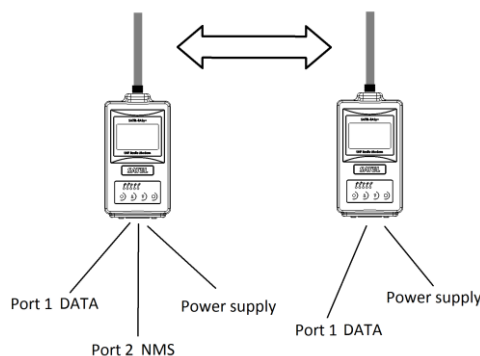

Figure 1.3 SATEL-EASy+ basic NMS set up

SATEL-EASy+ radio modem has two serial ports - *Port1* and *Port2*. One of the ports is configured as the DATA port (by default *Port1*) that is connected to the user application. The other port is the NMS port (by default *Port2*) that is connected to the serial port of the PC running SATEL NETCO NMS (or SATEL NMS PC) software.

The easiest way to accomplish the wiring is to use a two-port serial cable (e.g. part code CRS-NMS from SATEL).

SATEL-EASy+ ETH has a USB serial port and a Bluetooth RFCOMM serial port that can be used for DATA or NMS just like the physical serial ports of SATEL-EASy+. The device can also have separate TCP/UDP servers for data and configuration. NETCO SW can be used to connect to the diagnostics server like to the serial ports.

Modbus TCP is supported with SATEL-EASy+ ETH with routing *Offset 6* and *Length 1*. Pre-configured network design templates available in SATEL NETCO DESIGN and NMS SW tools. Additional information available from local SATEL distributors and SATEL technical support.

18.3 NMS - Usage

SATEL NETCO NMS (and SATEL NMS PC) software provide the user interface to NMS system. Refer to SATEL NETCO NMS (and SATEL NMS PC) User Guide for additional information.

18.4 NMS functionality

SATEL NMS provides useful tools for maintaining the radio network. The following functions are included in the SATEL NMS system:

- Status of the network can be obtained easily. Received Signal strength (RSSI) information, Voltage, Temperature and quality of the radio links can be monitored without disturbing user's data flow. SATEL NETCO NMS (and SATEL NMS PC) software collects statistics on the radio modems of the network.
- Alarms (triggered e.g. by a significant decrease in signal level of a radio link) are generated for the external system usage.
- The history of the parameters is saved to log files for later examination.
- Remote update of the setup i.e. the settings of a radio modem.
- Data communication tests. A full data communication test can be run to find out more detailed analysis of each radio link. Whenever needed this test indicate profoundly the quality of the radio communication.

18.5 Requirements for the user system

SATEL NMS fits the systems that are:

- Single master systems with point-to-multipoint network structure
- Based on polling protocol (the master polls the remotes regularly)
- Transferring user messages not larger than 1kByte

Other kinds of systems may also be possible but require careful consideration; in such cases the customer is advised to contact SATEL for more information.

Repeater stations are fully supported. While operating the monitoring system, radio data links are transparent. Because NMS data is invisible to the user's system, most user protocols are not interfered by NMS. However, note that on-line NMS always affects the real time operation of any system due to the extra information transferred. In some cases, this means that the parameter defining the timeout of the slave station reply must be increased. Depending on how much NMS information is required, NMS introduces an extra load of ~20...60 bytes per a message.

18.6 Designing Systems and Networks

The Routing window of SATEL NETCO NMS (or SATEL NMS PC) software provides a graphical tool for designing the radio network. It is used by simply dragging and dropping modem icons on the sheet and linking the modems and finally uploading these settings to individual modems.

The designing of any radio modem system requires very precise planning. Once the choices between devices, their locations, installation, maintenance etc. are clear, the project file for the system can be implemented by using SATEL NETCO NMS (or SATEL NMS PC) software tools. Please refer SW tools user manuals for more detailed description.

Please visit SATEL WEB pages for additional information:

<https://www.satel.com/products/software/>

Or contact SATEL technical support.

19 SOFTWARE FEATURE EXTENSIONS

SATEL-EASy+ can be upgraded with software features which can be released through DRM (Digital Rights Management). This allows the user to select proper functionalities from the functionality list. The following list explains the possible features with detail.

Following features are separately purchased, excluding SATEL NMS Support (YD0403) which is supported by default in SATEL-EASy+:

19.1 AES256 encryption (YD0402)

Provides an opportunity to use stronger over the air encryption.

19.2 SATEL NMS default config (YD0602)

When ordering SATEL-EASy+ radio modem, choosing SATEL NMS default config (YD0602) the default settings of the modem will be changed to SATELLINE-3AS NMS Compatible.

20 INSTALLATION

20.1 Installation of the radio modem

SATEL-EASy+ has four (4) fixing screw positions on its back side of the housing which can be used to attach the modem to a structure or to accomplish a grounding connection.

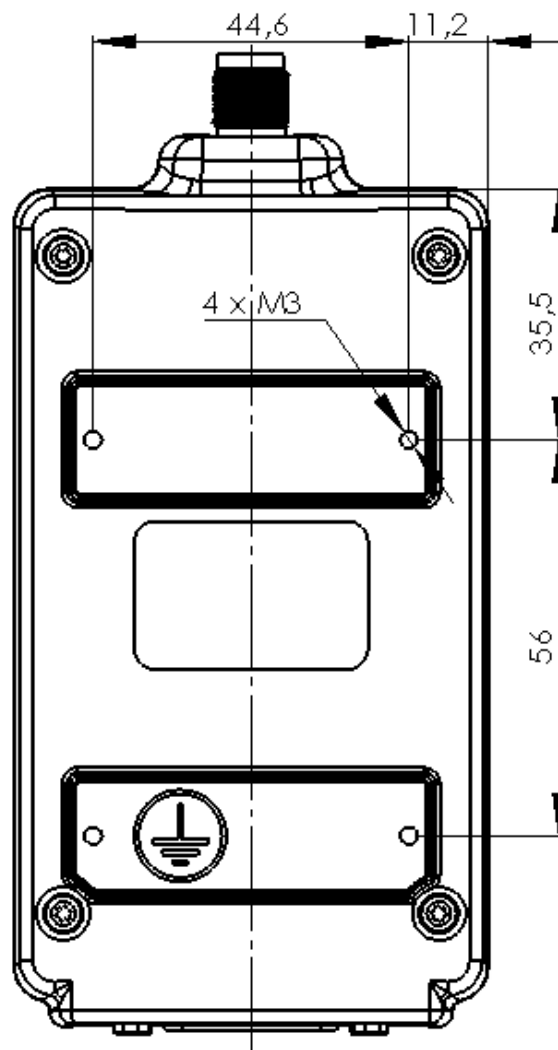

Figure 1.4 Mounting screw positions

20.1.1 Installation Requirements

Electronic devices are sensitive to external influences which should be taken into consideration while taking the device into operation. Proper place for assembling is necessary for good performance and long lifespan. Even though SATEL-EASy+ modem is built to withstand external vibrations, shocks, temperature fluctuations and high/low temperatures still those occurrences should be avoided as much as possible to maximize the durability and longevity of the product. High temperature decreases the lifespan of the components whereas vibration and shocks weaken the mechanical structure and can drastically affect the performance in use.

Should be noted that SATEL-EASy+ is not meant for direct outdoor use and to avoid moisture or high humidity issues EASy+ modem is preferable to use only indoors or outside inside of proper isolation against harsh weather conditions.

20.1.2 Installation Parts

Installation Parts are a series of adjacent parts which are used to attach the modem to a structure and perform the grounding of the device. Installation parts can be purchased separately from the supplier and is not automatically included with the modem. Installation parts includes the following parts: Installation plate, M3 screws (4pcs) and Velcro tapes (2pcs). Cable and connector needed to complete the grounding can be purchased separately from most of the hardware stores or online shops and is not included to the installation parts. Order code for the installation parts is WP0600.

20.1.2.1 Installation Plate

Installation plate can be used to make permanent installations to flat surfaces. Installation plate is made out of zinc plated steel sheet, and it has 4 screw positions on each of its corner. To ease the installation screws can be attached from the front side to the structure. Installation plate is included to installation kit which can be purchased separately.

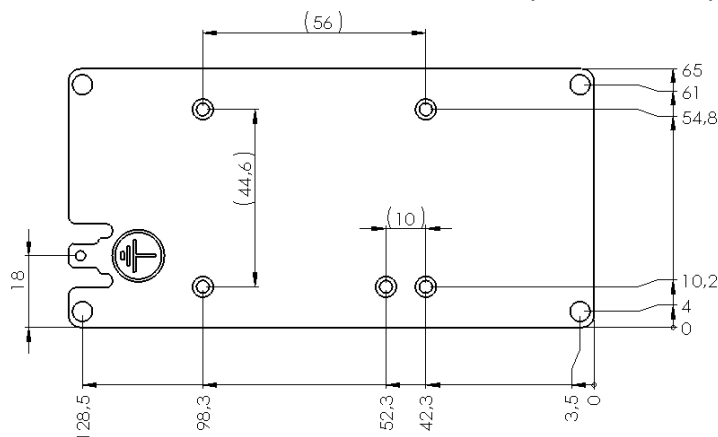

Figure 1.5 Installation plate and dimensions

20.1.2.2 Velcro tapes

SATEL-EASy+ can be attached to flat surfaces with simple Velcro tapes. This installation is rather temporary than fixed in situations where modem installation needs to be set up quickly without screws. Velcro tapes are included to installation kit which can be purchased separately.

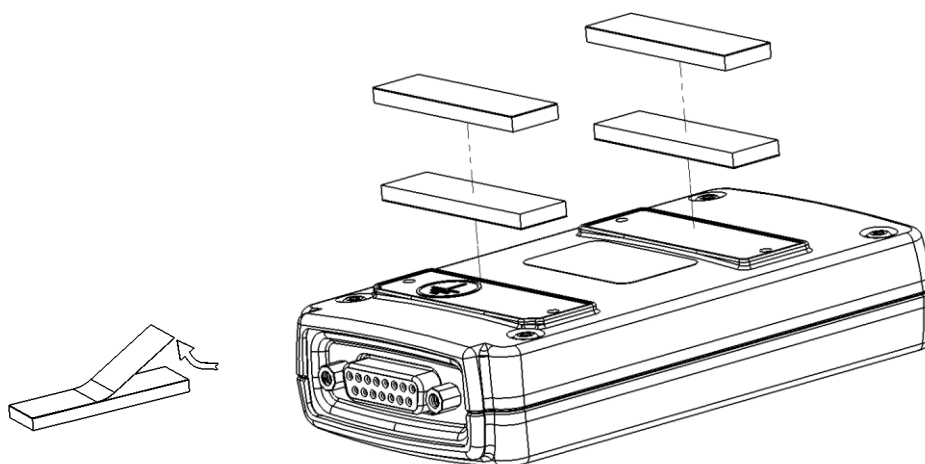

Figure 1.6 Velcro tape positions

20.1.3 DIN Installation Part

DIN installation part includes the necessary parts to attach the modem to a 35 mm DIN rail and it also includes the grounding parts as in the Installation Parts.

DIN Installation Part can be purchased separately from the supplier and is not automatically included with the modem. DIN installation part includes the following parts: DIN rail Installation plate with dual clips, M3 screws (4pcs). Order code for the DIN installation part is ME0220.

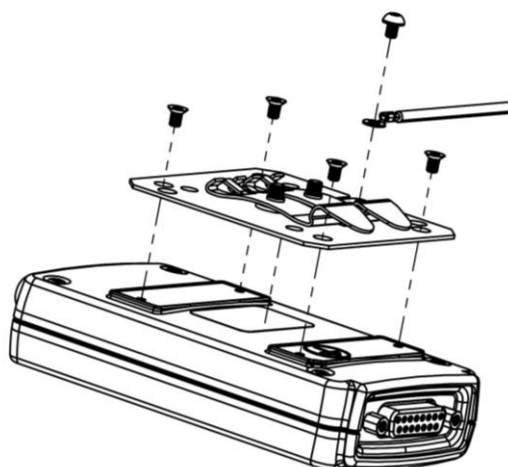

Figure 1.7 DIN rail installation plate

20.14 Grounding, using the housing

SATEL-EASy+ can be grounded directly using modem housing with its dedicated grounding point. Grounding point is marked to the housing with Ground – label. It is preferable to use the screw included with the modem shipment.

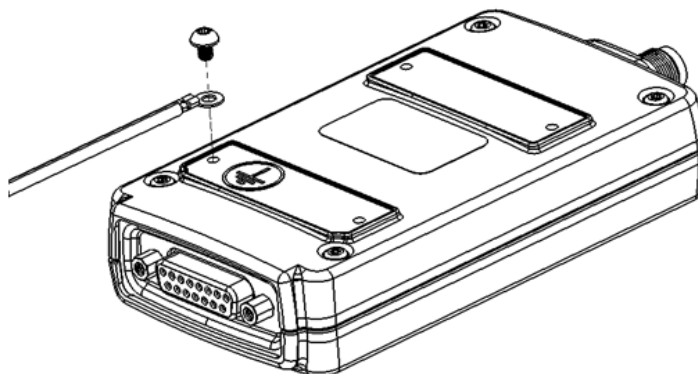

Figure 1.8 Grounding to the back of the housing

20.15 Grounding, using the installation plate

Installation plate can be used to accomplish the grounding between the modem and system grounding rail. Installation plate grounding position is marked with stamped Ground – sign. By using a proper connector and grounding cable user can create reliable grounding connection. Additional cable and connector should be purchased separately, see section “Grounding cable” for further information.

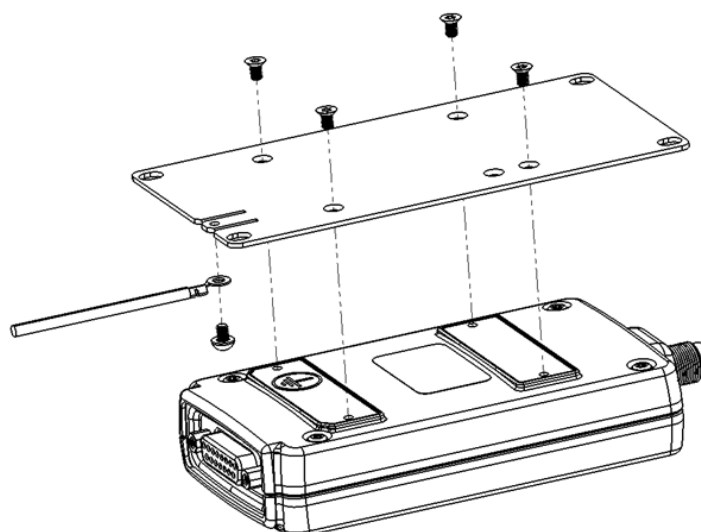

Figure 1.9 Grounding to housing

20.16 Grounding cable and screws

Grounding cable should be with $>1 \text{ mm}^2$ copper conductor with insulation, preferable green/yellow coded for easy ground recognition. Cable should be joined to grounding connector by crimp connection (pictured). Grounding should be terminated to a grounding rail or other reliable grounding source with shortest possible cable length to avoid ground loops and elevated resistances in cables. If longer cable is needed, cable thickness should be increased accordingly.

Two different screw types are included in the installation kit. Screw type A is M3 countersunk screw and is used to attach the installation plate to the modem housing. Screw type B is used for grounding connector attachment.

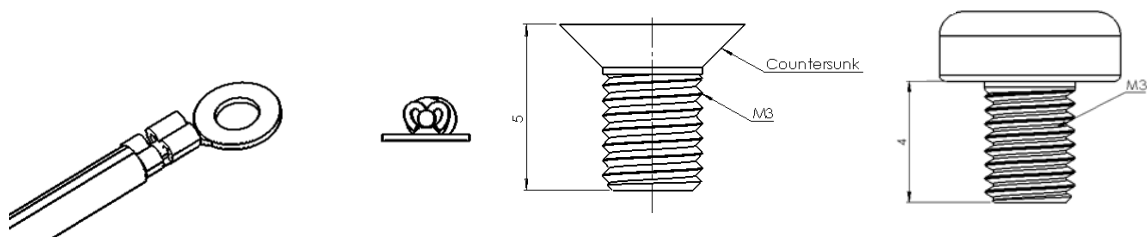

Figure 1.10 Grounding cable, connector, and screws A and B

20.17 Grounding the antenna

Grounding the antenna is recommended when antenna is located outside on a mast or long pole where it is prone to lightning strikes or other high energy disturbances.

Grounding is best to locate as near as possible to the expected disturbance to occur, in practise at the point where the antenna is fixed to a structure. Wiring the antenna ground and/or cable shield should be done to a ground rail or other reliable common ground with shortest possible cable length to avoid high resistance ground loops. If grounding cable is needed to be longer thicker cable should be used accordingly. Copper cable is preferred for highest conductivity. It is not recommended to use the mast only as a grounding conductor as its conductivity can't be always guaranteed.

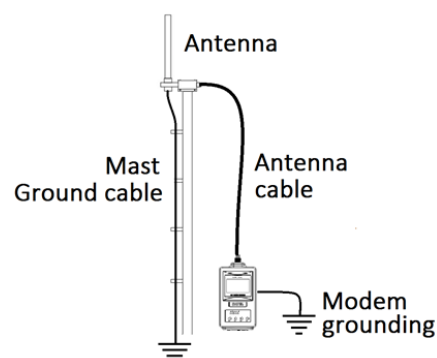

Figure 1.11 Grounding the antenna

20.2 Wiring SATEL-EASy+

NOTE!

When installing the cables of the serial interface, it is recommended to switch off operating voltage of all devices is off (POWER OFF condition).

20.2.1 RS-232 wiring - Port1 without handshaking

The simplest connection to PC serial port (RS-232) is depicted in the schematic below.

Note: DTR is not needed to be connected

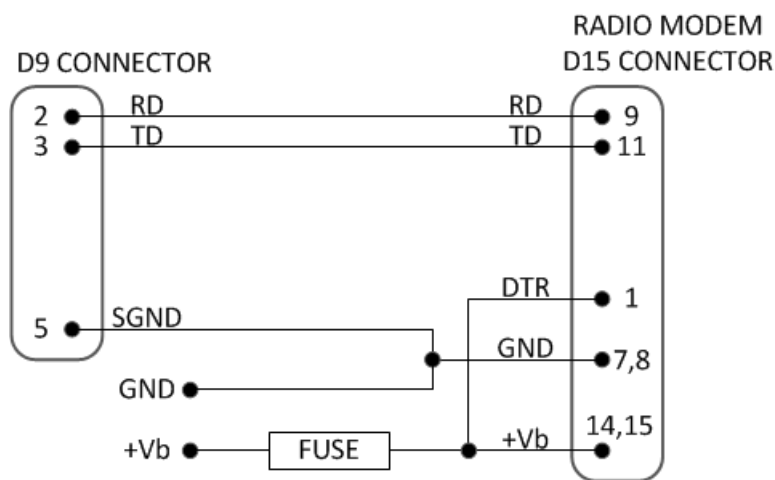

FUSE = 2 A slow

20.2.2 RS-232 wiring - Port1 and handshaking signals connected

A typical connection between the Port 1 of the radio modem and the PC serial port (RS-232) using the handshaking signals is depicted in the schematic below.

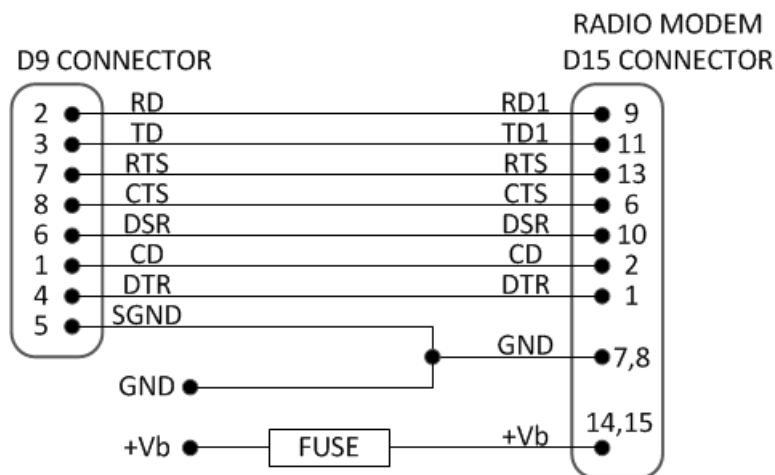

FUSE = 2 A slow

20.2.3 RS-422 wiring

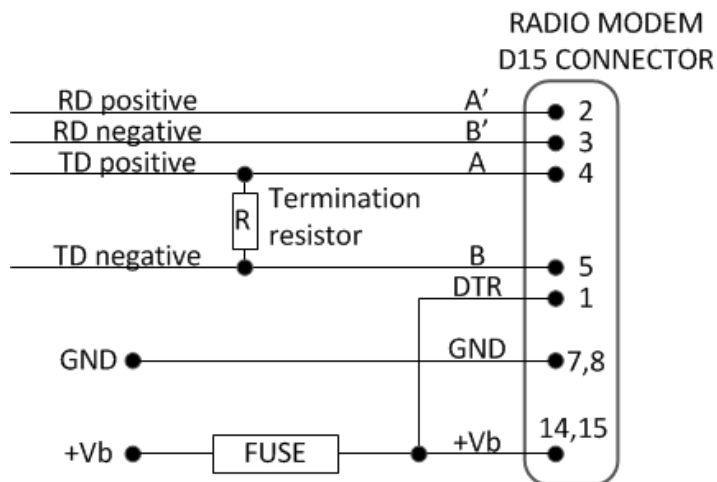

FUSE = 2 A slow

If the transmission lines are long the receiving end of the lines must be terminated using a separate termination resistor (typical values range from 100 -120 ohm depending on the characteristic impedance of the transmission line).

20.2.4 RS-485 wiring

Both ends of the transmission line should be terminated by connecting a separate terminating resistor between the positive and negative signal wire. Typical values range from 100 – 120 ohm depending on the characteristic impedance of the line.

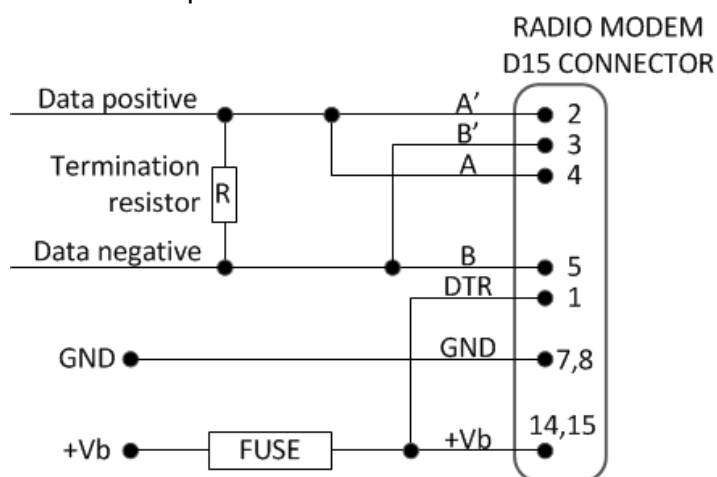

FUSE = 2 A slow

NOTE! The RS-485/422 standards define only the electrical parameters of the signals (signal level etc.). The connectors and the names of the signals are NOT defined. Different RS-485/422 standards or proprietary buses specify different names for the wires. Common signal names used are 'A' and 'B', '+' and '-' or 'hot' and 'cold'. Unfortunately, these names define the polarity

of the signals only for a specific system or specific equipment. In reality 'A' of one system can actually be 'B' of another. If the polarity is wrong, the data will be inverted. Usually the simplest way to solve the issue is the trial and error method, as RS-485 signals can be connected only two ways.

20.2.5 Programming mode adapter

The wiring below is for configuring the radio modem via the Programming mode. Switch position acts the following way; closed=ON=Programming mode, open=OFF=Data transfer mode. While the modem is in Programming mode (switch closed), modem has serial port parameters set to a known state of 38400N81 for easy accessing the modem. Programming mode also disables the radio interface functions (Tx/Rx).

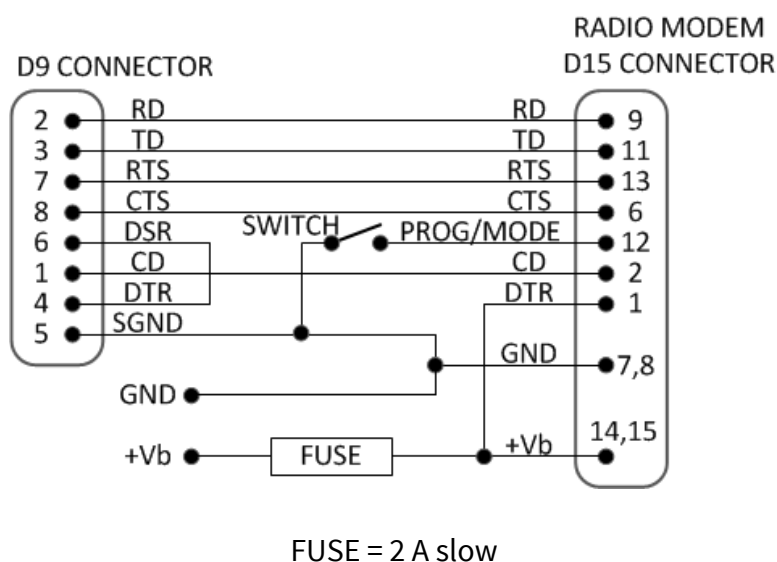

20.3 Antenna installation

20.3.1 Mobile equipment

- 1/4-wave antenna (wavelength at frequency of 450 MHz is approximately 70 cm)
- 1/2-wave antenna

The ideal installation position is vertical, and there should be at least 0.5 m of free space around the antenna. A separate ground plane should be placed under the 1/4-wave antenna (vehicle rooftop or the engine hood or trunk door are usually suitable). In problematic cases the most suitable type is a 1/2-wave antenna. It can be installed directly at the top of a pipe with the added benefit of gaining as much as free space around the antenna as possible. In case the antenna cannot be directly connected to the radio modem, a coaxial cable with 50-ohm impedance must be used between the antenna and the antenna connector.

20.3.2 Base stations

- Omni-directional antennas ($\frac{1}{4}$ -, $\frac{1}{2}$ - or $\frac{5}{8}$ -wave antenna)
- Directional antennas (Yagi /multi-element antenna or corner antenna)

The antenna should be installed in a vertical position. The exact location of the antenna depends on several factors, such as the size of the overall system and the coverage area terrain contours. A rule of thumb is that the base station antenna should be located at the highest point of the coverage area and as close to the centre of the coverage area as possible. The base station antenna can also be located inside a building, if the walls of the building do not contain metal.

20.3.3 General antenna installation instructions

The reliability and the achievable coverage of useful signal strength can be severely affected by the positioning of the antenna. Antenna and cable connectors should have gold-plated pins and sockets, as use of low quality connectors can lead to eventual oxidation of the connector surfaces, which in turn may degrade the contact and cause additional attenuation. Good quality tools and materials must be used when installing radio modems, antennas and cables. The weather tolerance of the materials used must also be taken into account. Installed materials must withstand all foreseeable weather conditions (frost, excess sun, direct UV-radiation, seawater etc.). Also, possible environmental pollution must be considered (acids, ozone etc.). Antennas must be installed well away from metallic objects. In the case of small antennas this distance should be at least $\frac{1}{2}$ m. With large antennas the distance should be >5 m and in case of repeater antenna combinations >10 m.

If the system contains a large number of radio modems, the best location for an antenna is the highest point of a building and possibly an additional antenna mast. If a separate antenna mast is used, the antenna can, if necessary, be installed sideways about 2...3 m from the mast itself.

When installing an antenna possible interference sources must be considered. Such interference sources are, for example:

- mobile telephone network base station antennas
- public telephone network base station antennas
- television broadcast antennas
- radio relay antennas
- other radio modem systems
- PC-related devices (approximately 5 m radius from antenna)

Please note that antennas are always tuned to a specific frequency range when ordering them. Simple antennas and antennas, which have been constructed of stacked Yagi-antennas, are typically rather broadband. As the number of Yagi-elements increases the frequency range becomes narrower.

When designing and installing a system it is advisable to prepare to test the system, and also to consider serviceability of the system. In particular cabling should be planned to allow easy access and to allow for maintenance. It is often practical to use long antenna cables, so that the radio modem can be installed far enough from the antenna itself to a location that is easily accessible.

The type of the antenna cable is dependent on the length of the antenna cable, and the following table can be used to select a suitable type:

Length	Type	Attenuation 10 m / 450 MHz
<5m	RG58	3.0 dB
<30m	ECOFLEX10	0.9 dB
<90m	ECOFLEX15	0.6 dB

If there is a line-of-sight path between the antennas a 6 dB power marginal is usually adequate. However, if the connection is built on the reflection and/or the knife-edge diffraction the path loss can vary even 20 dB depending on the weather conditions. In this case a short test can give a too positive result of the quality of the connection. Thus, the height of the antennas and topographical obstacles must be surveyed with great care. From time to time a marginal connection can be used if the data transmission protocol is well prepared for this and the data transmission that occasionally slows down does not cause any problems to the system.

Vertical polarised antennas (antenna elements are in vertical position) are often used in radio systems. In a system between a base station and substations vertical polarisation is recommended. The radio modem antenna cannot be mounted on the same level as the other substation antennas in the same building. The best way to distinguish from the other antennas situated in the neighbourhood is to mount the antennas as far as possible from each other on the altitude level. The best result is generally obtained when all the antennas are in the same mast. With an extra ground plane between the antennas more distinction can be obtained between the antennas in the mast.

Horizontal polarisation can be used in data transmission between two points. With the polarisation attenuation more distinction is obtained to vertical polarised systems. The influence of the directional patterns of the antennas must, however, be taken into consideration. If a distinction to another interfering antenna is wanted with the horizontal polarised antennas there must be a good attenuation of the back lobe. In addition to this the interfering radiator should be situated behind the antenna.

When a system does not demand the use of an Omni-directional antenna it is recommended that directional antennas are used e.g. two-element Yagi's in permanent external installations. Please note that as antenna amplification increases the setting of the direction of the antenna requires more attention.

Base stations in high places should be supplied with High-Q cavity filters. Please note that the higher the base station antenna, the larger the coverage area and in turn that the risk of interference is also increased.

SATEL recommends the use of a band-pass filter with a large Q in the antenna cable of the base station.

Example of an antenna installation: Long connection distances can be realised by using directional and/or amplifying antennas (G =Gain) and by installing the antenna high from the ground to avoid ground obstacles and overcome earth's curvature. Very high distances can be achieved with careful antenna, mast height and cable designing.

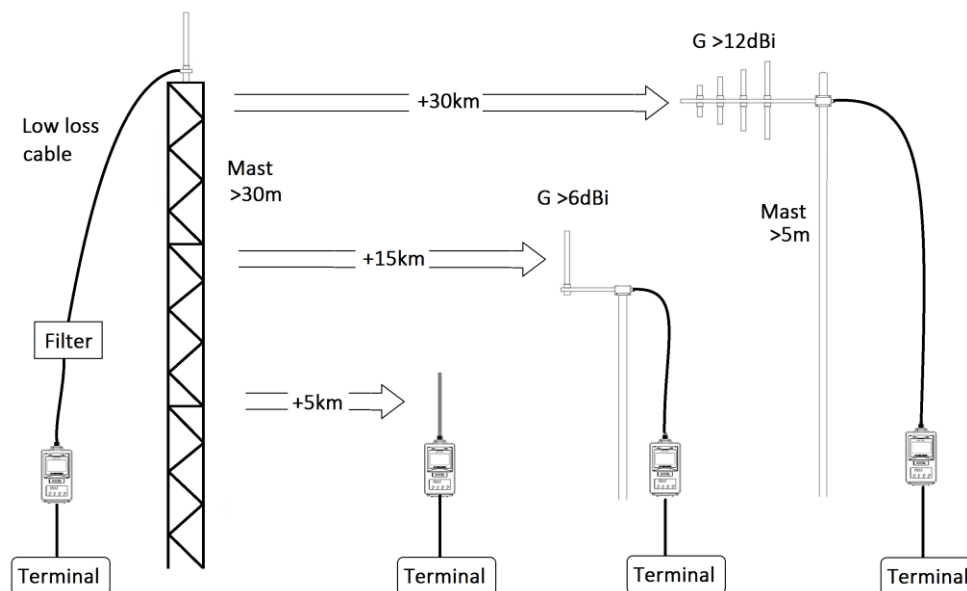

21 DESIGNING SYSTEMS

21.1 Factors affecting the quality and distance of the radio connection

- power of the radio transmitter
- sensitivity of the radio receiver
- tolerance of spurious radiations of the radio modulating signal
- amplification of transmitting and receiving antennas
- antenna cable attenuation
- antenna height
- natural obstacles
- interference caused by other electrical equipment

The transmitter power of the modems using 403 – 473 MHz frequency range is 1 W (maximum) and the sensitivity of the receiver better than -115 dBm. Thus in a flat area and in free space with a 1/4 wave antenna (antenna amplification 1dBi) and antenna height of 1 m communication distances of 3 to 4 km can be achieved. Distances may be considerably shorter in situations where there are metallic walls or other material inhibiting the propagation of radio waves.

Over long distances, increasing the height of antennas can often solve problems caused by natural obstacles. A ten-fold increase in distance can be achieved with the use of amplifying antennas. Frequent topographical variations over long distances may require that at least one of the antennas be raised to a height of 10 to 20 m.

If the antenna cable is more than 10 meters long it is necessary to use a low loss cable (< 0.7 dB /10 m) in order not to waste the antenna amplification. Adding a repeater station can also solve problematical radio connections. In systems with many base stations the RSSI-signal can be used to assist in choosing the base station with the best signal. A communications network can also be built with a combination of cables and radio data modems.

Modem tolerates normal levels of interference that occur. However, exceptionally high levels of interference can break through the safeguards and thus cause errors in data transfer. In mobile vehicle applications the range of operation can be increased by dividing the transmitted data into e.g. 50...500 byte long blocks and by re-transmitting the defected blocks.

A sufficient safety margin can be obtained by testing the communication path using extra 6 dB attenuation at the antenna connection and with slightly less effective antennas than those to be used in the final system.

21.2 Radio field strength

Radio signal strength must be good enough for successful data transfer. Where field strength is above a certain level, the operational results are very good. Below this level, a few dB marginal areas occur in which errors begin to be generated by noise and interference that will eventually lead to loss of connection.

The field strength is at its optimum level in open space, although increasing distance will still reduce it. It must also be remembered that one open space has different environmental and external factors to another, and that the effects on transmission quality must be taken into account when planning the system.

Ground, ground contours and buildings cause attenuation (loss of energy through absorption) and reflection of radio waves. Buildings reflect radio waves and therefore the effects of attenuation are not as acute when transmission is over a short distance.

However, the reflected waves will often be a bit delayed, and when they combine with the direct radio waves they interact in either a weakening or a strengthening way. This causes the fading effect in mobile systems. In reality very sharp signal drops spaced about 35 cm apart may occur. The attenuation may even reach 40 dB, normally less.

22 CHECK LIST

The following points must be taken into account when installing and configuring a radio modem:

1. All operating voltages of all the equipment concerned must always be switched OFF before connecting the serial interface cable.
2. When considering the exact placement of a radio modem and/or its antenna, the following points must be taken into account to guarantee optimal results:

The antenna should be installed in open space as far as possible from any possible sources of interference

The radio modem should not be installed onto a strongly vibrating surface

The radio modem should be installed in such a way as to minimise exposure to direct sunlight or excessive humidity.

3. To ensure reliable operation the voltage output of the power supply must be stable enough and the current capability of the power supply must be sufficient.
4. The antenna must be installed according to instructions.
5. Serial interface settings between the radio modem and the terminal unit must correspond to each other.
6. All radio modems in the same system must be configured using same settings (radio frequency, channel spacing and data field length).

23 ACCESSORIES

SATEL provides a wide selection of accessories and solutions for SATEL radio modems.

- Antennas
- Serial data / Power cables and adapters
- RF-cables
- Filters and lightning protectors
- Power supplies
- USB cables
- Ethernet cables

24 RECYCLING ELECTRIC WASTE (WEEE)

SATEL-EASy+ can withstand years of daily use and thousands of work hours, but when the device comes to its end of life stage it should be disposed properly. SATEL-EASy+ does not contain harmful materials that should be treated any special ways but as a general electronic waste. Many countries have laws and regulations towards e-waste recycling and organized receiving centres. See your local area laws and recommendations how to properly dispose electronic waste.

(WEEE = waste electrical and electronic equipment)

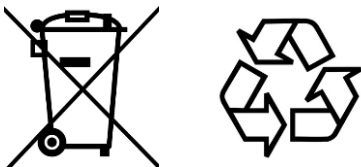

25 APPENDIX A

ASCII CHARACTER TABLE																	
D	H	A	D	H	A	D	H	A	D	H	A	D	H	A	D	H	A
0	0	NUL	43	2B	+	86	56	V	129	81		172	AC		215	D7	
1	1	SOH	44	2C	,	87	57	W	130	82		173	AD		216	D8	
2	2	STX	45	2D	-	88	58	X	131	83		174	AE		217	D9	
3	3	ETX	46	2E	.	89	59	Y	132	84		175	AF		218	DA	
4	4	EOT	47	2F	/	90	5A	Z	133	85		176	B0		219	DB	
5	5	ENQ	48	30	0	91	5B	[134	86		177	B1		220	DC	
6	6	ACK	49	31	1	92	5C	\	135	87		178	B2		221	DD	
7	7	BEL	50	32	2	93	5D]	136	88		179	B3		222	DE	
8	8	BS	51	33	3	94	5E	^	137	89		180	B4		223	DF	
9	9	HT	52	34	4	95	5F	_	138	8A		181	B5		224	E0	
10	A	LF	53	35	5	96	60	`	139	8B		182	B6		225	E1	
11	B	VT	54	36	6	97	61	a	140	8C		183	B7		226	E2	
12	C	FF	55	37	7	98	62	b	141	8D		184	B8		227	E3	
13	D	CR	56	38	8	99	63	c	142	8E		185	B9		228	E4	
14	E	SO	57	39	9	100	64	d	143	8F		186	BA		229	E5	
15	F	SI	58	3A	:	101	65	e	144	90		187	BB		230	E6	
16	10	DLE	59	3B	;	102	66	f	145	91		188	BC		231	E7	
17	11	DC1	60	3C	<	103	67	g	146	92		189	BD		232	E8	
18	12	DC2	61	3D	=	104	68	h	147	93		190	BE		233	E9	
19	13	DC3	62	3E	>	105	69	i	148	94		191	BF		234	EA	
20	14	DC4	63	3F	?	106	6A	j	149	95		192	C0		235	EB	
21	15	NAK	64	40	@	107	6B	k	150	96		193	C1		236	EC	
22	16	SYN	65	41	A	108	6C	l	151	97		194	C2		237	ED	
23	17	ETB	66	42	B	109	6D	m	152	98		195	C3		238	EE	
24	18	CAN	67	43	C	110	6E	n	153	99		196	C4		239	EF	
25	19	EM	68	44	D	111	6F	o	154	9A		197	C5		240	F0	
26	1A	SUB	69	45	E	112	70	p	155	9B		198	C6		241	F1	
27	1B	ESC	70	46	F	113	71	q	156	9C		199	C7		242	F2	
28	1C	FS	71	47	G	114	72	r	157	9D		200	C8		243	F3	
29	1D	GS	72	48	H	115	73	s	158	9E		201	C9		244	F4	
30	1E	RS	73	49	I	116	74	t	159	9F		202	CA		245	F5	
31	1F	US	74	4A	J	117	75	u	160	A0		203	CB		246	F6	
32	20	SP	75	4B	K	118	76	v	161	A1		204	CC		247	F7	
33	21	!	76	4C	L	119	77	w	162	A2		205	CD		248	F8	
34	22	"	77	4D	M	120	78	x	163	A3		206	CE		249	F9	
35	23	#	78	4E	N	121	79	y	164	A4		207	CF		250	FA	
36	24	\$	79	4F	O	122	7A	z	165	A5		208	D0		251	FB	
37	25	%	80	50	P	123	7B	{	166	A6		209	D1		252	FC	
38	26	&	81	51	Q	124	7C		167	A7		210	D2		253	FD	
39	27	'	82	52	R	125	7D	}	168	A8		211	D3		254	FE	
40	28	(83	53	S	126	7E	~	169	A9		212	D4		255	FF	
41	29)	84	54	T	127	7F		170	AA		213	D5				
42	2A	*	85	55	U	128	80		171	AB		214	D6				

26 APPENDIX B – DELAYS

26.1 Functional delays

Function	Delay
Wakeup time from STAND-BY to ON (controlled by DTR line)	<500 ms
Serial Interface, turn-around time of RS-232	0 ms
Serial interface, turn-around time of RS-485	<1 ms

26.2 Transmission related delays

The tables on the next pages show the typical values of the transmission delay using different sized data messages with SATEL-EASy+. The transmission delay is specified from the end of the transmission to the end of reception on the serial interface:

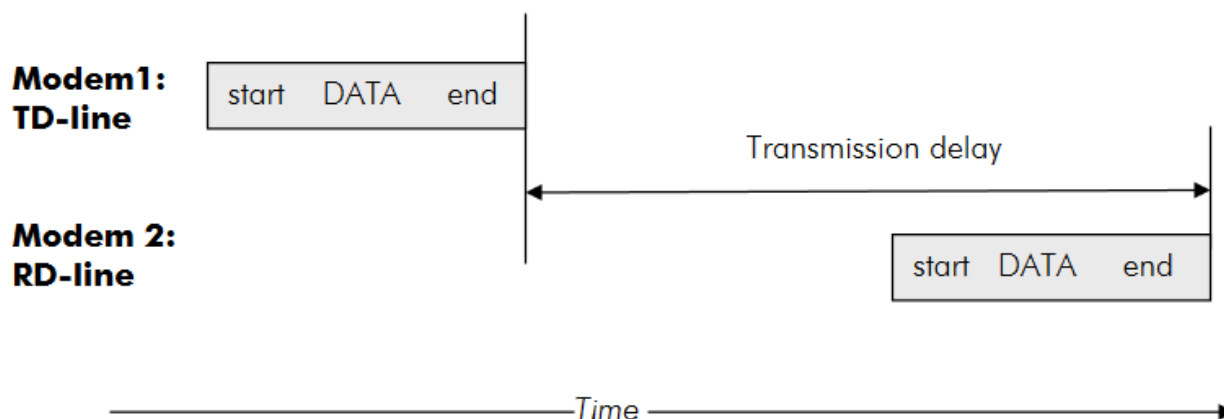

12.5 kHz channel spacing FEC OFF (Forward Error Correction function OFF)					
Data Speed	1 byte	10 bytes	100 bytes	500 bytes	
1200 bps	46	77	78	91	ms
4800 bps	39	66	84	86	ms
9600 bps	37	68	112	156	ms
19200 bps	37	72	80	292	ms
38400 bps	38	76	125	388	ms
115200 bps	38	44	113	418	ms

12.5 kHz channel spacing FEC ON (Forward Error Correction function ON)					
Data Speed	1 byte	10 bytes	100 bytes	500 bytes	
1200 bps	56	90	96	108	ms
4800 bps	50	87	127	130	ms
9600 bps	48	87	134	296	ms
19200 bps	48	87	192	484	ms
38400 bps	47	86	174	572	ms
115200 bps	46	46	149	580	ms

25 kHz channel spacing FEC OFF (Forward Error Correction function OFF)					
Data Speed	1 byte	10 bytes	100 bytes	500 bytes	
1200 bps	32	46	52	62	ms
4800 bps	25	42	46	48	ms
9600 bps	24	41	51	53	ms
19200 bps	22	42	57	86	ms
38400 bps	22	44	57	163	ms
115200 bps	22	24	54	189	ms

25 kHz channel spacing FEC ON (Forward Error Correction function ON)					
Data Speed	1 byte	10 bytes	100 bytes	500 bytes	
1200 bps	38	58	64	76	ms
4800 bps	30	53	61	62	ms
9600 bps	29	54	70	78	ms
19200 bps	29	52	84	155	ms
38400 bps	28	51	83	233	ms
115200 bps	28	27	74	273	ms

Transmission delays are in milliseconds (10% marginal) vs. the size of a message (bytes) to be transmitted.

Contact information

SATEL Oy
Meriniitynkatu 17
P.O. Box 142
FI-24101 Salo
FINLAND
Web: <https://www.satel.com/>
Phone: [+358 2 777 7800](tel:+35827777800)